



Bolted Joint Training for Engineers and Designers

*A training course delivered by Matrix Engineering, an
approved provider of Bolt Science® Training*



© Copyright Bolt Science Limited 2019

Information contained in this document has been obtained and developed by Bolt Science Limited from sources considered to be reliable. However, neither Bolt Science nor its authors guarantee the accuracy or completeness of any information published herein and neither Bolt Science nor its authors shall be responsible for any errors, omissions, or damages arising out of the use of this information.



Bolted Joint Training for Designers and Engineers

14hr Training Course Content

©Copyright Bolt Science Limited 2020

Following is an outline of the material topics covered in the standard 14hr training course. Following presentation of the background theory, problems will be presented relating to the topic. Full answers are provided in the course documentation. The course includes case studies which are drawn from the automotive, naval, off-highway, power generation and railway industries. The course also includes hands-on demonstrations of torque tightening, torque and angle tightening and excessive bearing stress. Each student will be provided with a notebook which contains the presentation slides, a simplified design guide, example calculations, and an appendix with bolt and joint properties.

Customized Training: The course content can also be modified to suit specific requirements of a company or organization. Customization may include unique fastener sizes, materials or conditions or specific problems or topics provided by the client.

Introduction to Course

- *Introductions*
- *Primary Bolted Joint Application Types*
- *PV Racking Bolted Joints – Unique!*
- *Bolted Joints – More to it than you may have thought*
- *Dunning-Kruger Effect*
- *Class Content*
- *Reference Books and Standards*

Introduction to Threaded Fasteners

- *Know the meaning of thread terminology.*
- *Background to modern threads - the roles of Whitworth and Sellers and the development of the metric thread.*
- *Learn the difference between a fine rather and coarse thread and advantages/disadvantages of each.*
- *Be aware of the principal bolt and nut strength property classes and how they should be specified.*
- *The basic profile of unified and metric thread forms.*
- *Thread tolerance positions and grades and the different tolerance classes that are available.*

Strength of bolts

- *The principles of bolt elongation, bolt stress and load and gasket stress.*
- *Yield, tensile strength and proof load properties.*
- *Details of common bolting specifications.*
- *Bolt and nut head markings and identification of correct components.*
- *Nut/bolt combinations, nut strength versus bolt strength.*
- *Upper and lower temperature limitations of common bolting materials.*
- *Relationships between bolt size, area, stress and bolt elongation and load.*
- *Factors determining the strength of a thread.*
- *Tests completed to establish the strength of threads, the original work of Eli Slaughter.*
- *How the stress area was established.*
- *Determination of the stress area of a thread. elongation and load.*

Methods of Tightening Threaded Fasteners

- *Overview of the methods used to tighten bolts.*
- *Load-angle of turn graph for a bolt tightened to failure.*
- *Torque controlled tightening method.*
- *Torque-angle tightening below the yield point.*
- *Projected angle tightening method below the yield point.*
- *Yield point tightening using incremental angle method.*
- *Yield point tightening method using slope measurement.*
- *Torque-angle tightening method into the plastic region.*
- *Yield control tightening plus an angle increment.*
- *Limited re-use of bolts sustaining plastic deformation.*
- *Bolt tensioning using hydraulic tensioning method.*
- *Tension indicating methods using load indicating bolts and washers.*
- *Application of ultrasonic technology and other instrumentation in bolt tightening.*

Torque Control Tightening

- *What is meant by a tightening torque?*
- *What are the consequences of not applying sufficient torque to a bolt?*
- *How torque is absorbed by a nut/bolt assembly.*
- *The relationship between the tightening torque and the resulting bolt preload (tension).*
- *The factors which affect the torque-tension relationship.*
- *The nut factor method of determining the correct tightening torque.*
- *Using the full torque-tension equation to determine the appropriate tightening torque.*
- *Example calculation of how to determine the correct tightening torque.*
- *Scatter in the bolt preload resulting from friction variations.*
- *Determining the bolt preload (tension) resulting from a tightening torque.*
- *Prevailing torque fasteners (such as those containing a nylon insert) and how it affects the torque distribution and what is the correct torque to use.*
- *Tests to determine the coefficient of friction of threaded fasteners.*

Torque Tightening Tools

- *Problems associated with the tightening of multi-bolt joint.*
- *Torque Wrenches*
- *Torque Multipliers*
- *Impact Wrenches*
- *Pulse Tools*
- *Nut Runners/DC Torque Tools*

Torque Tightening Demonstration with a Skidmore Device

- *Typical torque tension equations.*
- *Example calculations – M10 Class 10.9*
- *Demonstration of the preload scatter achieved using torque tightening.*
- *Effect of repeated tightening of Electro-Plate Zn bolt and nuts.*
- *Demonstration of Torque-Angle Tightening*
- *Demonstration of excess bearing stress and the effect of washer.*

Torque Auditing

- *Principles of torque auditing.*
- *Dynamic and static torque measurements.*
- *Methods of checking installed torque values.*
- *The "Crack-On" method of torque checking.*
- *The "Marked Fastener" method.*
- *The "Crack-Off" method of torque checking.*
- *Torque "Go-No-Go" Assessment.*
- *Problems with Torque Auditing.*

Tightening Procedures

- *Problems associated with the tightening of multi-bolt joint.*
- *Elastic interaction.*
- *Single pass tightening sequence.*
- *Two pass and multi-pass tightening sequences.*
- *Tightening sequences for non-circular bolted joints.*
- *Tests investigating the effects of elastic interaction.*
- *Use of multiple tightening tools.*
- *Ways to check the tightening sequence.*
- *The solder plug method.*
- *The use of pressure sensitive film.*

Overview of Fastener Failure Mechanisms and Causes

- Overview of the ways threaded fasteners can fail.
- Manufacturing related quality defects.
- Design related quality defects.
- Failure by insufficient preload - examples including joint slip, joint separation and gasket sealing failures.
- Fatigue failure of bolts.
- Thread Stripping Failures - internal and external threads.
- Bolt overload from applied forces.
- Bearing stress under the bolt head or nut face.

Thread Stripping

- Identify the cause of thread stripping.
- Be able to establish the shear area of an internal or external thread.
- How the tapping drill size affects the strength of the bolt thread.
- How the radial engagement of threads affects thread strength and the failure load.
- Use the information provided on the course to calculate the internal and external thread areas and the force needed to cause the threads to strip.
- Be able to establish the length of thread engagement needed to prevent thread stripping.

Hydrogen Embrittlement of Fasteners

- Background to hydrogen embrittlement.
- Fracture characteristics associated with this type of failure.
- The cause and mechanism of hydrogen embrittlement.
- Checking for hydrogen embrittlement - paraffin test.
- Lower temperature heat treatment after plating.
- Stress corrosion cracking and the influences of the operating environment, the bolt stress and the bolt material.

Galling of Threaded Fasteners

- Background and explanation of galling.
- Types of fastener material and finishes susceptible to galling.
- Examples of thread galling.
- Approaches that are used to prevent/minimize galling

Preload Losses Due to Embedment

- Explanation of embedment
- Current understanding of embedment and parameters which affect it.
- Embedment and the Joint Diagram
- Loss of preload due to embedment – springs in series.
- Best guess values from VDI 2230.
- Effect of joint thickness on embedment losses.
- Effects of paint in bolted joints.
- Methods of reducing embedment preload loss

Fasteners at Low or Elevated Temperatures (optional)

- Overview of the effect of decreasing or increasing the temperature that the joint was assembled at.
- Temperature ranges of common bolting materials.
- The effect of differential thermal expansion
- Transitory temperature effects.
- Effect of temperature on the yield strength of common bolting materials.
- Effect of temperature on the modulus of elasticity.
- Stress relaxation and the effect on the bolt preload.
- Example calculation accounting for differential thermal expansion and stress relaxation.

Self- Loosening of Threaded Fasteners

- *An overview of the research completed over the last 50 years into establishing the cause of the self-loosening of threaded fasteners.*
- *Appreciate the forces that are acting on the threads that tend to self-loosen a fastener. Why fine threads can resist loosening better than coarse threads. The inclined plane analogy.*
- *Junker's theory on self-loosening of fasteners and why fasteners self-loosen.*
- *The Junkers/transverse vibration test for fasteners.*
- *Preload decay curves and the effectiveness of various fastener types in resisting vibrational loosening.*
- *Conclusions from the research and how loosening can be prevented.*

Bolts in Direct Shear

- *Friction grip and direct shear bolted joint designs.*
- *Issues with bolts loaded in direct shear.*
- *Shear capacity in direct shear.*
- *Example calculation - direct shear loading.*
- *Joints consisting of multiple bolts.*
- *Joints sustaining direct shear and axial loading.*
- *Example problems for the student to resolve.*

Shear Loading of 'Friction Grip' Bolted Joints

- *What is meant by an eccentric shear load?*
- *Understand the slip process that can occur with shear loaded joints.*
- *Learn what is meant by the instantaneous center of rotation for the joint.*
- *Be able to calculate the reactions of individual bolts when shear forces are applied to the joint.*
- *Perform example calculations so that you have confidence to use them in practical applications.*

Combined Tension and Shear Loading of 'Friction Grip' Bolted Joints

- *Learn the methods that can be used to analyze joints subjected to combined tension and shear loads.*
- *Understand what is meant by prying and its effects.*
- *Methods that can be used to determine the neutral axis of the joint when combined tension and shear loads are acting*
- *Perform example calculations so that you have confidence to use them in practical applications.*

Overview of Joint Diagrams and Load Factors

- *Bolt and joint acting like springs.*
- *Explanation of basic joint diagram.*
- *Comparison of hard and soft joints.*
- *Effect of bolt preload.*
- *Effect of applied axial loading.*
- *Joint separation.*
- *Load factor explanation and calculation.*
- *Example problem.*
- *Bolt and joint stiffness calculations.*
- *Calculation of applied load resulting in joint separation.*
- *Effect of alternating load.*
- *Effect of load introduction location.*

Overview of FEA Methods to Develop Bolt Reactions

- *When should FEA be used?*
- *Short description of the three most common FEA methods.*
 - *Method 1: Fully Detailed Solid Model.*
 - *Method 2: Simplified Solid Model.*
 - *Method 3: Simplified Pre-Tensioned Beam Element.*
- *Advantages/Disadvantages of each method.*
- *Validation of FEA Model.*
- *Factors often missed in FEA.*

VDI 2230 Systematic Calculation of Bolted Joints

- *Why are systematic methods important?*
- *Development of Joint Diagrams.*
- *VDI 2230 Background and range of validity.*
- *Key concepts of VDI 2230, failure modes of bolted joints.*
- *VDI 2230 - The Calculation Steps.*
- *Limitations of VDI 2230.*
- *Software of VDI 2230 calculation.*

Preload Requirement Charts

- *A simple method to prevent the majority of bolting issues.*
- *Determining the maximum and minimum preloads.*
- *How to calculate the likely embedding loss.*
- *Establishing the axial force requirement.*
- *Establishing the shear force requirement.*
- *Determining the total force requirement for the joint*
- *Example calculations.*
- *Ways in which a bolting design problem can be resolved.*
- *Statistical considerations in bolted joint design.*

A Simplified Design Guide

- *Systematic step, by step guide to aid designers and design engineers to design a bolted joint from scratch using simplified and conservative assumptions.*

In-Class Project – (optional)

- *In class project which can be solved in teams, individually by students or the instructor.*
- *Re-design of the from caster wheel mounting bracket bolted joint.*
- *Discussion about the assumptions and how to apply engineering judgement to decide if the solution is 'good enough'.*

Fastener Finishes and Corrosion (optional)

- *Background and types of corrosion.*
- *The galvanic series and barrier and sacrificial protection.*
- *The mechanism of galvanic coupling.*
- *Provision of sacrificial protection of steel fasteners.*
- *Effect of the coating thickness on thread dimensions.*
- *Maximum coating thickness for class 6g threads.*
- *Salt spray testing and the performance of various finishes.*
- *Main types of fastener finishes being used.*

Typical Questions Addressed in the Training

- *What tightening torque should be applied to the fasteners?*
- *How do you quantify in a calculation methodology the bolt preload scatter associated with the tightening process?*
- *Should the nut or bolt be tightened, or does it not matter?*
- *What are the advantages in using other tightening methods rather than torque control?*
- *What ways can be used to check the 'tightness' of a previously tightened fastener?*
- *Is the drive joint shown likely to fail under the given dynamic loading condition?*
- *What is likely to be the problem and how can the issue be rectified?*
- *Can it be anticipated that the joint will fail due to?*
 - *Insufficient preload?*
 - *Bolt Fatigue Failure?*
 - *Thread Stripping?*
 - *The bolts/nuts self-loosening?*
 - *Bolt Overload?*
 - *Thread Stripping?*
- *If there is a problem identified, how can joint be modified so that it will be fit for purpose?*
- *How can the effects of joint relaxation be quantified at the design stage?*
- *Do I really need to use some kind of locking device?*
- *Why a stronger bolt is not necessarily better?*
- *Is it better for a bolt to fail by tensile fracture during the tightening process or sustain thread stripping?*
- *Under what specific circumstances does a fastener self-loosen and how can it be prevented?*
- *Why are many locking devices that research indicates are ineffective, still being used?*
- *What tests can be completed to validate this joint?*

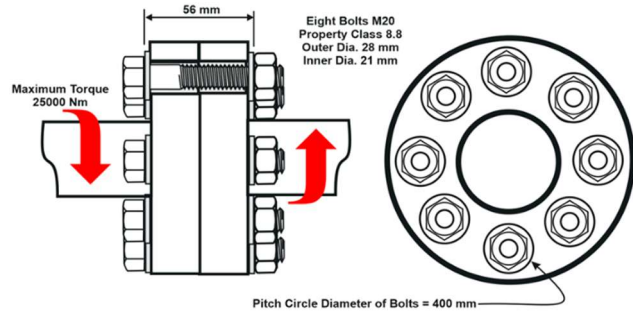

Training Course Instructor

The training course will be presented by Jon Ness, PE. Jon has over 30 years of engineering and design experience related to the development of mobile equipment components and sub-systems, including dynamically loaded bolted joints. His work has included the design of multiple gear boxes, powertrain systems, engine installations and the development of test and validation plan strategies. He has taught numerous classes related to Failure Modes and Effects Analysis and Bolted Joint Design for design engineers.