



Building and Industrial Applications Department
Building and Industrial Energy Systems Division
Lawrence Berkeley National Laboratory

Fundamentals of Solar PV Bolted Joint Loosening and Prevention

Jon Ness¹

Gerald Robinson²

¹Matrix Engineering Consultants

²Lawrence Berkeley National Laboratory

January 2026



Disclaimer

This document was prepared as an account of work sponsored by the United States Government. While this document is believed to contain correct information, neither the United States Government nor any agency thereof, nor the Regents of the University of California, nor any of their employees, makes any warranty, express or implied, or assumes any legal responsibility for the accuracy, completeness, or usefulness of any information, apparatus, product, or process disclosed, or represents that its use would not infringe privately owned rights. Reference herein to any specific commercial product, process, or service by its trade name, trademark, manufacturer, or otherwise, does not necessarily constitute or imply its endorsement, recommendation, or favoring by the United States Government or any agency thereof, or the Regents of the University of California. The views and opinions of authors expressed herein do not necessarily state or reflect those of the United States Government or any agency thereof, or the Regents of the University of California.

Lawrence Berkeley National Laboratory is an equal opportunity employer.

Copyright Notice

This manuscript has been authored by an author at Lawrence Berkeley National Laboratory under Contract No. DE-AC02-05CH11231 with the U.S. Department of Energy. The U.S. Government retains, and the publisher, by accepting the article for publication, acknowledges that the U.S. Government retains a non-exclusive, paid-up, irrevocable, world-wide license to publish or reproduce the published form of this manuscript, or allow others to do so, for U.S. Government purposes.

Fundamentals of Solar PV Bolted Joint Loosening and Prevention

Prepared for the
U.S. DOE Office of Energy Efficiency and Renewable Energy (EERE), Solar Energy
Technologies (SETO) Office
U.S. Department of Energy

Principal Authors

Jon Ness¹

Gerald Robinson²

¹Matrix Engineering Consultants

²Lawrence Berkeley National Lab

Lawrence Berkeley National Laboratory
1 Cyclotron Road, MS 90R3147
Berkeley CA 94720-8136

January 2026

Acknowledgements

The work described in this study was conducted at Lawrence Berkeley National Laboratory and supported by the U.S. DOE Office of Energy Efficiency and Renewable Energy (EERE) and the U.S. Department of Energy Solar Energy Technologies (SETO) Office under Contract No. DEAC02-05CH11231 under Contract No. DE-AC02-05CH11231.

The authors thank the following experts for reviewing this report (affiliations do not imply that those organizations support or endorse this work):

James Elsworth

National Renewable Energy Lab

Steve Hogan

Retired

Table of Contents

Acknowledgements	i
Table of Contents	ii
Table of Figures	iv
List of Tables	v
Background, Scope & Objectives	vi
Glossary	viii
1. Introduction	1
2. Relaxation Loosening (non-rotational)	2
2.1 Explanation and Types of Relaxation Loosening	2
2.1.1 Yielding of Solar PV Bolted Joint Components	2
2.1.2 Fretting Wear.....	6
2.1.3 Embedment of Surfaces within a Mounting System Bolted Joint	6
2.1.4 Differential Thermal Expansion or Contraction – Within the Solar PV Bolted Joint ...	10
2.2 Minimizing Relaxation Loosening in Solar PV Bolted Joints	12
2.2.1 Increase the L/D Ratio of the Bolted Joint.....	12
2.2.2 The Use of Belleville Springs in Solar PV Bolted Joints	13
3. Self-Loosening (rotational loosening)	13
3.1 Friction, a Critical Parameter for Bolted Joint Reliability	13
3.2 Explanation of Self-Loosening	14
3.3 The Use of Torque Stripes to Detect Self-Loosening	15
3.4 Junker Test	15
3.5 Prevention of Self-Loosening	16
3.5.1 How is shear capacity created in a particular solar PV bolted joint?.....	17
3.5.2 What is the shear load applied to a particular solar PV bolted joint?	17
3.6 Devices Effective at Resisting Self-loosening	18
3.6.1 Lockbolts.....	18
3.6.2 Thread Lockers/Adhesives.....	19
3.6.3 Wedge Lock Washers	19
3.6.4 Caution on Using Locking Fasteners / Devices	20
3.7 Devices/Methods Ineffective at Resisting Self-loosening	20
3.7.1 Helical spring washers (a.k.a. lock washers).....	20
3.7.2 Serrated flange bolts and nuts	21
3.7.3 Lock Nuts (a.k.a. prevailing torque nuts)	21
4. Top 10 Tips to Avoid Loosening in Solar PV Mounting System Bolted Joints	23
5. Conclusions	24

6. References	25
7. Addendum A – Relaxation Due to Embedment Case Study Calculations	26
8. Addendum B – Differential Thermal Contraction Case Study Calculations	28

Table of Figures

Figure 1: Summary of Failure Mechanisms Reported in SETO Solar PV bolted joint Failure Survey	vi
Figure 2: Summary of Postulated Failure Causes for Failures Reported in SETO	vii
Image 3: Examples of loose solar PV bolted joints. (left and center) See the gap between the nut and the bearing surface; (right) note the wear on the surface caused by the bolt and nut slipping.	1
Image 4: Example of improperly designed or assembled bolted joint – missing washer.	2
Image 5: The bolt pretension is concentrated at bolt and nut bearing surfaces resulting in high contact stress.	3
Image 6: Evidence of compressive yield of an aluminum surface due to the high compressive stress under the bearing surface (without a washer).	3
Image 7: Evidence of compressive yield of a ‘soft’ washer tightened on a standard, round clearance hole.	4
Image 8: Example of bending of washer mounted on an oversized slot.	4
Image 10: Example of a thin purlin yielding due to the pretension in the top-down clamp bolt	5
Image 9: Example of a ‘hat’ section yielding due to the pretension of in bolt.	5
Image 11: Problematic star washer placement in module through-bolted structural bonded joint	6
Image 12: Relative repeated joint slip results in fretting wear at the joint interface.	7
Image 13: Example of fretting wear of G90 purlin at the joint interface due to repeated joint slip.	7
Image 14: When a PV module through-bolted joint is assembled and tightened, the asperities are pressed together, leading to high localized compressive stresses and plastic flattening of the asperities.	7
Figure 15: Theoretical relaxation of pretension due to embedment over time in a typical solar PV mounting system bolted joint.	8
Image 16: A bolt behaves like a spring when it is tightened.	9
Image 17: Typical PV Module Top-Down Clamp Bolted Joint	10
Image 18: Typical PV Module Through-Bolted Joint	10
Image 19: Information used in the calculation of relaxation due to differential thermal contraction in examples #1 & 2	12
Image 20: Belleville spring in the unloaded state takes the form of a conical spring that flattens at a known spring rate.	13
Image 21: Friction within the solar PV bolted joint prevents joint slip and the resulting self-loosening in a properly designed and assembled bolted joint.	14
Image 22: Solar PV joints, such as the PV module through bolted joints, will self-loosen if the joint repeatedly slips.	15
Image 23: Torque stripes detect whether self-loosening has occurred after installation.	16
Image 24: Solar PV bolted joint with evidence of repeated joint slip and self-loosening.	16
Figure 25: Test results shown here were compiled from previous tests completed by Bolt Science-LTD, Huck International, Inc. and Henkel Corp.	17
Image 26: Lock bolts are immune to self-loosening.	19
Image 27: Pre-applied thread locker is activated upon assembly of the bolted joint.	20

Image 28: Wedge lock washers must be assembled in pairs.	21
Image 29: Wedge lock washers must be assembled in pairs.	21
Image 30: Typical helical spring washer.	22
Image 31: Helical washer in a loose module through-bolted joint.	22
Image 32: Typical serrated flange bolt and nut.	22
Image 33: Nylon insert, prevailing torque nut (a.k.a. “lock nut”)	22
Image 34: Typical all-metal prevailing torque nut (a.k.a. lock nut)	22
Image 35: The use of nylon lock nuts can be problematic in solar PV joints unless they are correctly specified.	23

List of Tables

Table 1: Summary of Case Study Results: Relaxation due to embedment calculation for a typical PV module top-down clamp joint vs through-bolted joint	Error! Bookmark not defined.
Table 2: Summary of coefficients of thermal expansion for common PV mounting system bolted joints.	Error! Bookmark not defined.
Table 3: Summary of Case Study Results: Relaxation in a typical PV module top-down clamp due to differential thermal contraction	Error! Bookmark not defined.

Background, Scope & Objectives

The photovoltaic (PV) industry has long reported anecdotal accounts of systems exhibiting intermittent or chronic fastener loosening, including joints that fail to maintain preload despite multiple retightening attempts. These occurrences are frequently, and often incorrectly, attributed to installer errors, vibration, or loading beyond design expectations (e.g., extreme weather events). Loose fasteners have serious implications and can significantly impact solar PV systems' performance, reliability, and safety. However, effective bolted joint design and proper assembly practices can mitigate or eliminate loosening.

Until the US Department of Energy's Solar Energy Technologies Office (SETO) funded research on fasteners and solar PV structures, there was a notable gap in understanding the causes of loosening in solar PV systems. This Guidance document section aims to fill that gap so industry stakeholders can specify, design, procure, and install more reliable fastener strategies, bonding, and solar PV structures.

As part of the SETO-funded research project titled Maturing Bolted Joint Technologies in Solar PV Structures (Prime Contract No. DE-AC02-05CH11231), a team conducted structured interviews with diverse stakeholders in the PV industry, gathering valuable insights into the characteristics, pervasiveness, and cost impacts of solar PV bolted joint failures (including loosening). The team interviewed over 28 expert respondents, providing a comprehensive understanding of the structural reliability of 17,000 systems with a combined capacity of over 94 GW.

The structured interviews yielded many valuable findings, including the prevalence of fastener and module-top-down clamp loosening. Of the 80 reported solar PV bolted joint failures, nearly 44% were reported as loosening (see Figure 1). The team assessed that 'installer error' accounted for only 13% of the identified causes. Less than 1% of the solar PV bolted joint failures discussed during the interviews were due to Acts of God, in which wind or snow loads exceeded the design loads. In other words, nearly all PV bolted joint failures occurred at less than the design wind and snow loads. A larger fraction (37%) came from mounting system 'design issue' related causes (see Figure 2).

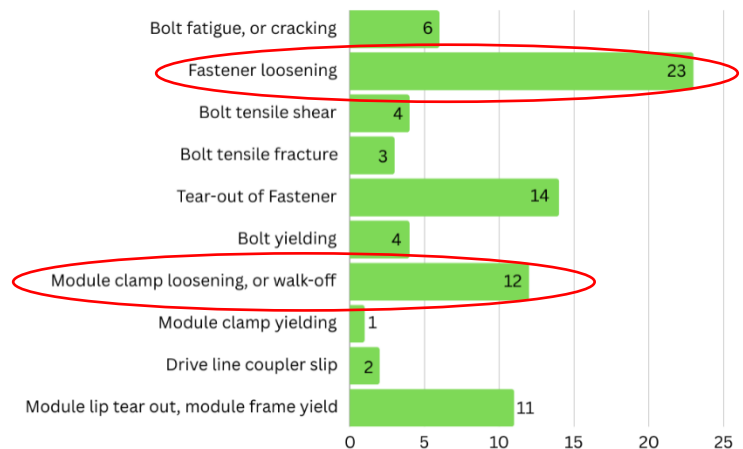

Figure 1: Summary of Failure Mechanisms Reported in SETO Solar PV bolted joint Failure Survey

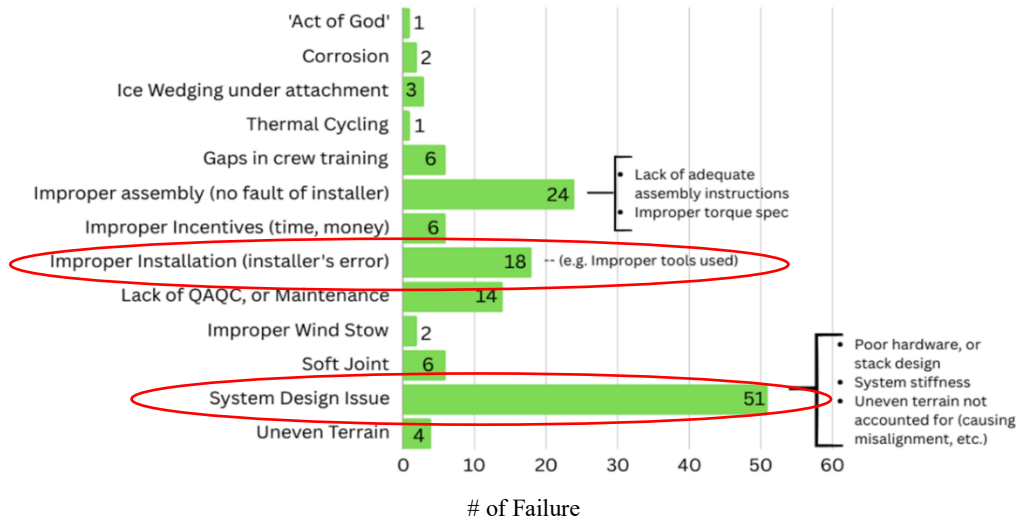

Figure 2: Summary of Postulated Failure Causes for Failures Reported

For years, anecdotes about loose fasteners on PV mounting systems have been widely shared; the structured interviews substantiated these issues and found them to be more common than previously assumed. This issue could be a contributing factor to increased O&M costs and diminished structural reliability of solar PV mounting structures.

This report illuminates the types, causes, and methods for preventing common loosening in solar PV structural and structural-bonded bolted joints. The objective is to help solar PV mounting system manufacturers design more reliable bolted joints that are less prone to loosening, and to help field engineers diagnose and address loosening issues in the field.

Clarification: “Bolted Joints”



In this chapter, the term bolted joint is assumed to mean any fastened joint that is joined together with threaded fastener hardware, such as a bolt, screw, or nut (see the Glossary section for the definitions of bolt and screw).

The report does not address loosening in PV module lip clips & clamps or module frame wedges.

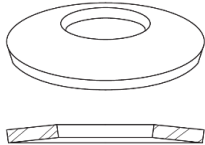
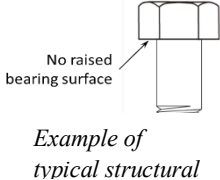
Glossary

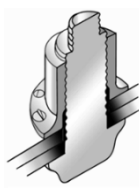
Term	Definition
Asperities	The microscopic peaks and valleys found on the surface of mating components in a bolted joint.
Belleville Spring (a.k.a. Belleville washer or conical spring washer)	<p>A conical, disc-shaped spring washer that deforms elastically under compression and is commonly used in bolted joints to help maintain clamp load by compensating for small dimensional changes in the joint due to relaxation or thermal expansion/contraction.</p> <p>The washer is named after Julian F. Belleville, a French engineer who contributed to its development.</p> 
Bolt	<p>An externally threaded fastener that does not contain a raised bearing surface under the head and is typically used in structural applications. By code, a bolt must be tightened by rotation of the nut.</p> <p>Solar PV mounting systems commonly utilize structural bolts in joints where the fasteners are ½” (M12) or larger. The term bolt is widely used to describe an externally threaded component in a solar PV mounting system, including screws, and this is a misnomer.</p> 
Bolted joint	For this report, the term bolted joint is assumed to mean any fastened joint joined with threaded fastener hardware, such as a bolt, screw, or nut.
Bonded joint	A general term that describes a joint that creates an equipotential (low resistance) electrical connection between exposed conductive components of the PV mounting structure. Bonded joints reduce the risk of electric shocks when an electrical fault current passes through the mounting structure.
Clamp load	The compressive force exerted by the tightened bolt or screw on the joint members holds the components together.
Coefficient of thermal expansion	A material property that quantifies the extent to which a material expands or contracts with temperature changes. It is defined as the fractional change in length per unit change in temperature.
Compressive yield	The stress level at which a material begins to deform plastically under compressive loading. It represents the point where the material transitions from elastic behavior (where it returns to its original shape upon unloading) to plastic behavior (where permanent deformation occurs).
Embedment	Localized plastic deformation of asperities at contact interfaces within a fastened joint due to compressive loads resulting from pretension and applied loads.
Failure mechanism	A failure mechanism is a deviant physical condition or state described by nouns and adjectives (e.g., fastener shear fracture, fastener fatigue failure, top-down clamp yielded, etc.) and often causes a Failure Mode.
Faying surface	A term commonly used in structural engineering that describes the contact

	<p>surface between two or more components joined by a bolt (i.e., joint interface). These surfaces are clamped under compressive force during assembly and tightening of the bolted joint. The condition (e.g., roughness, flatness, coating, cleanliness) and frictional properties of the faying surfaces directly influence the joint's ability to resist shear loads through friction (in slip-critical or friction-type joints) and affect stress distribution across the joint.</p>
Fretting wear	<p>Localized wear of asperities within a fastened joint is caused by small-amplitude relative motion between contacting surfaces under load, typically at the faying (mating) surfaces due to vibration, cyclic loading, or thermal expansion/contraction.</p>
Helical spring washer (a.k.a. lock washer)	<p>A type of washer designed in a helical shape with an axial split that provides a spring-like action when compressed.</p> 
Junker Test	<p>A common name used to describe a test that assesses the ability of a particular screw, nut, washer, or threaded locker to resist self-loosening behavior when the joint repeatedly slips. Gerhard Junker originally developed the test apparatus and procedure and became a precursor to the modern industry standards DIN 25201 and ISO 16130.</p>
Loose bolted joint	<p>Any fastened joint (bolted joint) that is joined together with threaded fastener hardware (such as a bolt, screw, or nut) in which the initial bolt pretension has been significantly reduced—due to relaxation, self-loosening, or other mechanisms—such that the joint can no longer reliably transfer loads without relative movement, separation, or loss of functionality.</p>
Lock bolt	<p>A mechanically fastened, two-piece structural fastener composed of a pin and a collar, designed to create a high-strength, vibration-resistant joint. During installation, the pin is pulled by a specialized tool, drawing joint components together and plastically deforming the collar, locking it permanently into annular grooves on the pin.</p> 
Microencapsulated thread locker	<p>A type of pre-applied thread adhesive that is applied in a dry, inactive state and remains dormant until assembly. It consists of tiny microcapsules containing an activator that breaks open and mixes upon tightening the fastener, initiating the adhesive curing process.</p>
Pretension (a.k.a. preload)	<p>The initial tension force created in a bolt or screw when it is tightened results in a clamp load in the joint.</p>
Prevailing torque	<p>The torque to overcome intentional friction in fastener threads created by a non-metallic insert (e.g., nylon) or deformed threads. This torque exists before the fastener fully engages the mating surface.</p>
Prevailing torque nut-all metal (a.k.a. metal locknut)	<p>A type of nut that requires torque to overcome intentional friction in fastener threads created by deformed threads. Unlike a free-spinning nut, it requires</p>

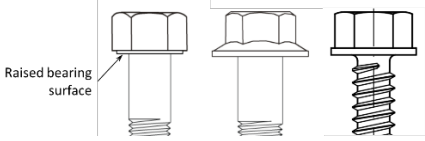
	additional torque to install and remove.	
Prevailing torque nylon insert (a.k.a. nylon locknut)	A type of nut that requires torque to overcome intentional friction in fastener threads created by nylon insert. Unlike a free-spinning nut, it requires additional torque to install and remove.	
Relaxation loosening (a.k.a. non-rotational loosening)	A general loosening process where the initial pretension in the bolt or screw created when it was tightened decreases over time without rotation between the internal and external threads due to material yield, fretting wear, or embedment.	
Screw	An externally threaded fastener that contains a round bearing surface under the head. A screw can be tightened by rotating the screw or the nut. Solar PV mounting systems commonly contain screws in joints where the fasteners are smaller than 1/2" (M12).	 <p><i>Examples of common screws - hex cap, flange head and self-tapping</i></p>
Self-loosening (rotational loosening)	Self-loosening is a specific loosening process that affects solar PV bolted joints that are repeatedly overloaded in shear and where the joint repeatedly slips. When self-loosening occurs, the initial pretension in the bolt (clamp load in the joint) decreases over time due to rotational loosening between the nut and bolt.	
Slip critical	A joint that transmits shear loads or shear loads in combination with tensile loads in which the bolting assemblies have been installed in accordance with Section 8.2 of RCSC: <i>Specification for Structural Joints Using High-Strength Bolts</i> , to provide a pretension in the installed bolt (clamping force on the faying surfaces) and with faying surfaces that have been prepared to provide calculable resistance against slip	
Solar PV joint	The assembly of components (fasteners, clips, washers, brackets) in a PV mounting system used to fasten <u>structural</u> joints includes module attachment, racking, tracker interconnections, as well as attachment to underlying structures not otherwise covered by AISC 360.	
Solar PV Mounting System	A term commonly used in the solar photovoltaic (PV) industry to describe PV mounting, racks, and tracker structures, whether they are fixed or movable.	
Structural joint	A general term used to describe a joint that is a critical element of the load path between the solar PV module and the earth.	
Structural bonded Joint	A joint is a critical element of the structural load path between the solar PV module and the earth, and a low-resistance electrical connection between exposed conductive components within a PV mounting system.	
Threaded fastener	A general term that describes the hardware, such as a bolt, screw, or nut, that is used to join two or more components mechanically.	
Traditional structural	A general term that describes fasteners (bolts, nuts, and washers) that fall	

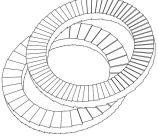
fastener	<p>under the guidance of AISC 360 and/or RCSC: Specification for Structural Joints Using High-Strength Bolts. The fasteners typically include:</p> <p>Bolts 1/2" or larger and controlled by ASTM F3125, ASTM A307, ASTM F1852, and ASTM F2280.</p> <p>Nuts 1/2" or larger and controlled by ASTM A563</p> <p>Washers 1/2" or larger, controlled by ASTM F436 and ASTM F959</p>
Wedge lock washer	<p>A self-locking washer system designed to prevent self-loosening in joints that repeatedly slip. The system consists of two interlocking washers with cam faces on the inner surface and radial ridges on the outer surface.</p> 

1. Introduction

Although often underestimated, threaded fasteners are critical components in photovoltaic (PV) mounting systems—including module mounting, racking, and tracking structures. These relatively low-cost elements create bolted joints that connect structural and non-structural components. While some joints support auxiliary elements such as junction boxes, most form integral parts of the structural load path, transferring forces between the PV modules and the earth.

PV mounting system structural bolted joints must reliably carry static loads (e.g., dead, live, snow) and dynamic loads (primarily wind) (Yibing Lou, 2024). In some PV mounting systems, these joints may also create an electrical bond, establishing equipotential connections between exposed electrically conductive components. A typical utility-scale PV installation may contain millions of such bolted joints, highlighting their critical role in overall structural reliability and safety.

While bolted joints are mechanically straightforward in concept, their load transfer behavior can be complex, particularly under dynamic loading. PV mounting systems are lightweight and flexible compared to other steel structures (i.e., buildings and bridges). As a result, they may experience significant deflections during wind events, amplifying forces on individual joints. This amplification can lead to loading that exceeds initial design expectations (Cain, 2015). The structural reliability of PV mounting systems is further challenged by the potential for bolted joint loosening, especially when joints are improperly designed, specified, fabricated, or assembled. The complexity of bolted joint loosening is not well understood within the photovoltaic. It may occur as an early, one-time event or a maintenance concern requiring periodic re-tightening.

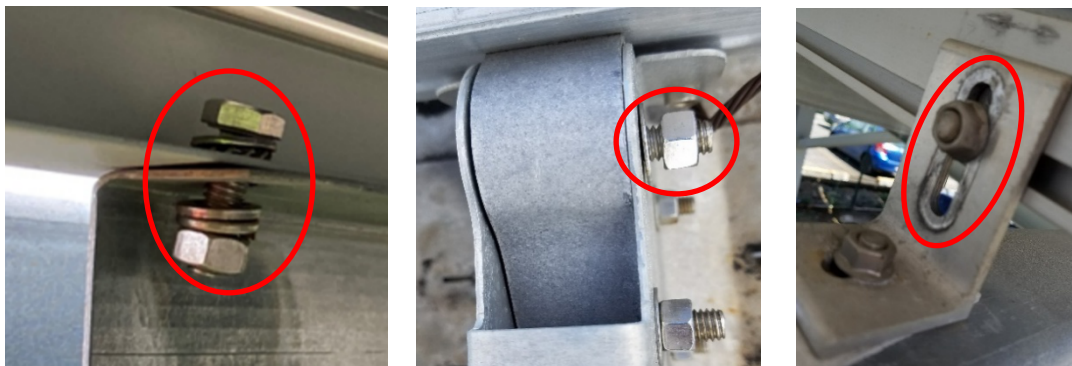

Image 3: Examples of loose solar PV bolted joints. (left and center) See the gap between the nut and the bearing surface; (right) note the wear on the surface caused by the bolt and nut slipping.

Extensive research from other industries on dynamically loaded bolted joints has identified two primary loosening mechanisms: **relaxation loosening** (non-rotational) and **self-loosening** (rotational) (Bickford, 2022). These findings directly apply to PV mounting systems and provide a technical foundation for the subsequent sections of this report (see Image 3)

2. Relaxation Loosening (non-rotational)

2.1 Explanation and Types of Relaxation Loosening

Relaxation is a general loosening process in which the initial pretension in the bolt (and clamp load in the joint) decreases over time without rotation between the internal and external threads. It is often called non-rotational loosening (Bickford, 2022).

Relaxation in solar PV bolted joints can occur through four distinct mechanisms. The first two, yield of joint components and fretting wear, are problematic and should be avoided. The latter two, embedment and differential thermal contraction, are expected and should be accounted for in the design process. The sections below describe the factors contributing to these relaxation mechanisms and offer practical strategies to reduce or prevent them.

2.1.1 Yielding of Solar PV Bolted Joint Components

Improperly designed or assembled solar PV bolted joints may loosen due to permanent deformation (yielding) of one or more joint components (VDI, 2015). To prevent chronic loosening, designers and installers should avoid conditions and causes that lead to joint component yielding.

Common causes of the yielding of joint components include:

- ***Lack of washer:*** Field inspections of PV mounting systems have revealed bolted joints that are frequently missing washers (see Image 4). When an assembler tightens a hex-head bolt or nut without a washer, the concentrated compressive stress beneath the small bearing surfaces of the bolt head or nut increases significantly (see Image 5). This stress often exceeds the compressive strength of aluminum and structural steel, leading to localized yielding (see Image 6) and long-term preload relaxation. In addition to pretension effects during assembly, compressive yielding may also result from in-service joint loading, posing a significant reliability concern.



Image 4: Example of improperly designed or assembled bolted joint – missing washer.

Cap screw head and
nut bearing surfaces

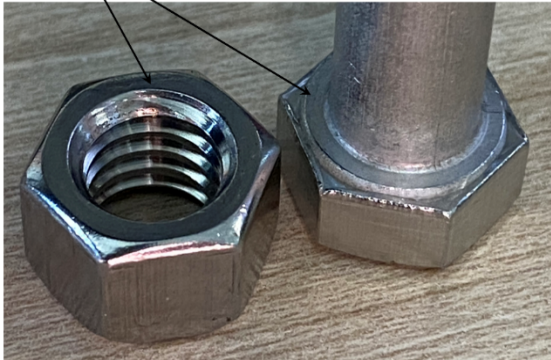

Image 5: The bolt pretension is concentrated at bolt and nut bearing surfaces resulting in high contact stress.

Evidence of compressive
yield because the washer
was missing.

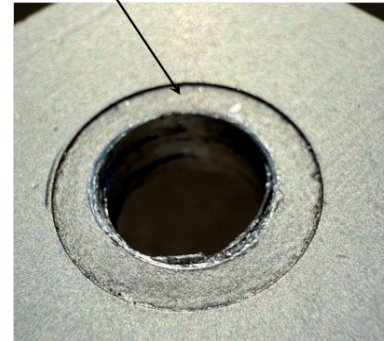
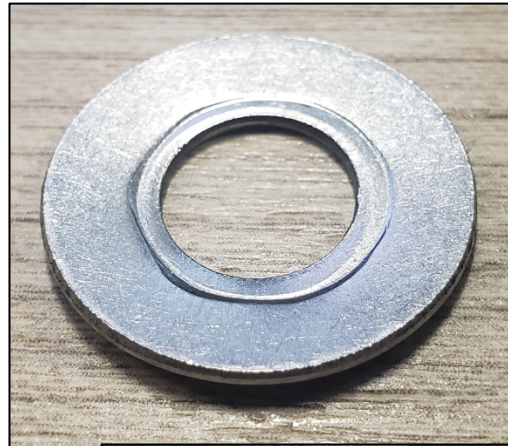

Image 6: Evidence of compressive yield of an aluminum surface due to the high compressive stress under the bearing surface (without a washer).

- Solution: Structural solar PV bolted joints using plain hex-head bolts and nuts should include a properly specified washer to distribute the bolt pretension over a larger contact area and reduce the compressive stress. Flanged bolts and nuts could be used instead of washers to achieve a similar effect.
- ***Improperly specified washer:*** Simply specifying “a washer” is insufficient to prevent relaxation. To be effective, the washer specification must account for joint properties, fastener head size, pretension level, washer material and thickness, and the clearance between the bolt and the hole or slot. Improperly specified washers can lead to significant relaxation.
 - The use of unhardened washers (a.k.a. soft washers) should be avoided. They often yield due to compressive stress generated beneath the bolt and nut-bearing surface during tightening and in-service loading. Unhardened washers can cause significant relaxation in the solar PV bolted joint, compromising joint

reliability (see Image 7).

- Solution: Washers should be specified as hard or harder than the bolt/nut tightening against them (as verified by microhardness testing). If this requirement is met, the washer will resist yielding at the contact surfaces under the bolt and nut-bearing surfaces, even if the bolt is over-tightened. **



- Using relatively thin washers (less than 0.0625" thick), oversized clearance holes, or slots should be avoided, especially if the washer does not fully cover the slot. Thin washers often yield during tightening or in-service loading due to high bending and localized stress in the underlying joint component. This deformation can lead to significant relaxation, compromising the reliability of the solar PV bolted joint. (see Image 8).

- Solution: Oversized holes and slots require washers sufficiently thick to distribute bolt pretension uniformly and remain flat after tightening. Guidelines

for specifying washers for oversized holes and slots were developed as part of this project and are included in this document.



Image 7: 'soft' washer clearance

Image 8: Example of bending of washer mounted on an oversized slot.

Additional details are provided in the report *Proposed Specifications for Clearance Holes and Washers* by Ness and Robinson (2026).

- Soft Joints: A bolted joint containing an air gap is often called a soft joint. This configuration creates an indirect load path and is generally unsuitable for critical structural applications, as the clamped components are less stiff and often weaker than the bolt, which limits the achievable pretension (VDI, 2015).

To improve the load-carrying capacity of soft joints, the clamped members should be thick enough to sustain both the bolt pretension and service loads without yielding. If the members are too thin, they may yield during tightening or under applied loads, leading to significant relaxation and compromising the reliability of the solar PV bolted joint (see Images 9, 10).

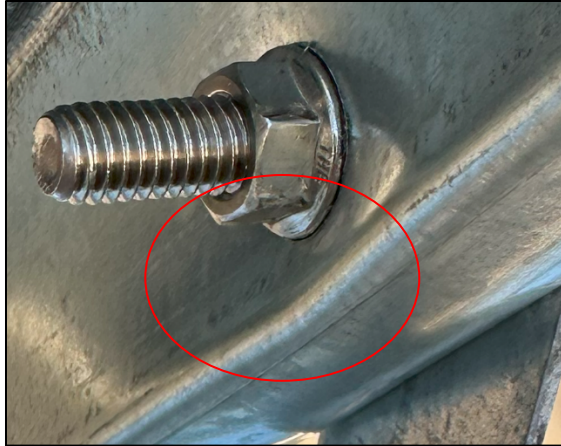

Image 9: Example of a ‘hat’ section yielding due to the pretension of in bolt.

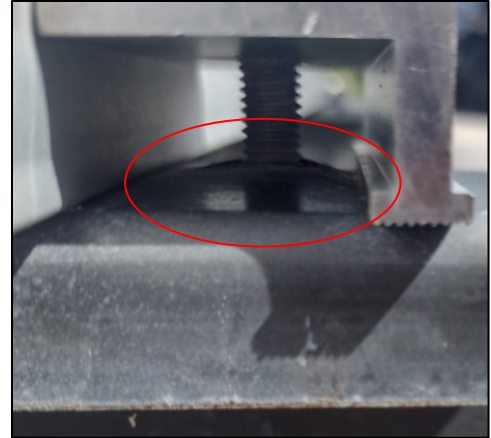

Image 10: Example of a thin purlin yielding due to the pretension in the top-down clamp bolt.

- Solution: Soft joints should be designed so the clamped members are thick enough to avoid yielding when the bolt is tightened to its full tensile capacity. In other words, the bolt should fracture before the joint member yields. This design challenge is often addressed in other industries using a spacer to eliminate the air gap. A detailed discussion of this approach is beyond the scope of this report.
- Use of Improvised Bonding Device—Star Washer: Some contractors use stainless-steel external-tooth (star) washers as improvised bonding devices for solar PV modules to meet NEC grounding and bonding requirements (see Image 11).

The washer’s sharp protrusions pierce the anodized, nonconductive surface to establish an electrical connection when tightened. Although most mounting system manufacturers disapprove of this method, some electrical inspectors permit its use. Star washers are low-cost and can effectively create electrical bonds in non-structural joints. However, field experience has shown that they can cause problems when used in structurally bonded joints, such as module through-bolted joints, exposed to dynamic loading. (See the Glossary for a definition of a structural bonded joint.)

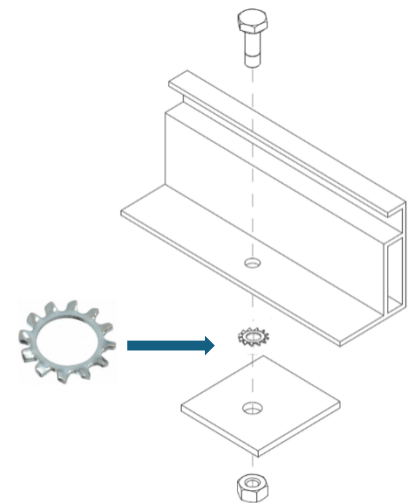

Image 11: Problematic star washer placement in module through-bolted structural bonded joint

Examinations of failed joints revealed compressive yielding beneath the star washer protrusions. The bolt pretension and applied loads became concentrated at these small contact points, causing the module frame to yield during or shortly after tightening. As a result, through-bolted joints bonded with star washers often relaxed, even after repeated retightening. An additional discussion on the bonding of structural joints and the use of star washers can be found in *Exploring Electrical Bonding in PV Structural Joints* by Ness and Wigginton (2026).

- **Solution:** Star washers should not be used as an improvised way to create an electrical bond in mounting system bolted joints exposed to dynamic loading, unless approved by the mounting system manufacturer, and certified under UL 2703

2.1.2 Fretting Wear

Fretting wear is a form of surface damage of the faying surfaces of a solar PV bolted joint subjected to repeated slip as shown in image 12 (Bickford, 2022) (VDI, 2015). It is caused by repeated slips of joint surfaces under high contact pressure, which wears down surface asperities. Fretting wear can remove protective coatings or even base material, leading to significant relaxation (see Image 13)

Solution: Critical solar PV bolted joints should be designed and assembled with sufficient pretension to prevent slip at the faying surfaces under dynamic loading. Preventing slip eliminates the primary cause of fretting wear.

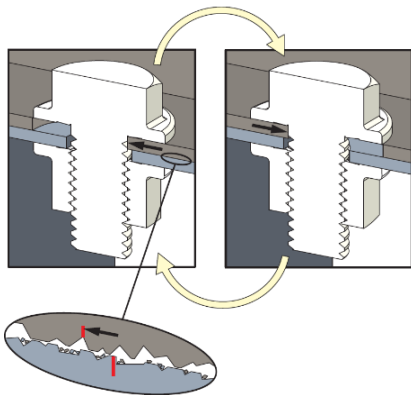

Image 12: Relative repeated joint slip results in fretting wear at the joint interface.

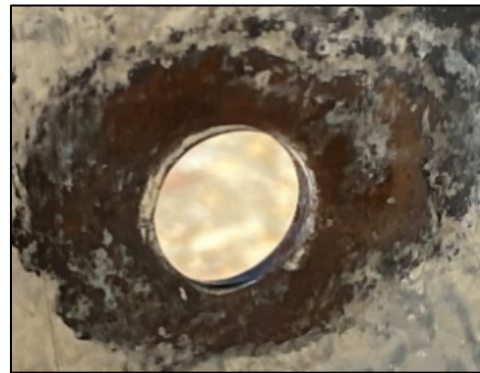

Image 13: Example of fretting wear of G90 purlin at the joint interface due to repeated joint slip.

2.1.3 Embedment of Surfaces within a Mounting System Bolted Joint

Although fasteners, joint plates, and washers in a bolted joint may appear smooth, microscopic examination reveals that these surfaces are covered with fine ridges and grooves known as asperities (see Image 14) (Bickford, 2022).

These asperities are pressed together when the joint is tightened, creating highly localized compressive stresses at their contact points. These stresses often exceed the material's local yield strength, causing plastic deformation and flattening of the asperities. This results in a

slight reduction in the total clamped thickness of the joint—an effect known as **embedment**.

Additional plastic flattening may continue if the joint is exposed to external influences such as vibration, thermal cycling, or fluctuating mechanical loads during field operation. The total reduction in clamped thickness caused by embedment is called the **embedment distance** (f_z) (VDI, 2015).

The embedment distance for a specific bolted joint depends on the number of interfaces, material properties, surface finish, and applied loads. Plastic deformation due to embedment eventually stabilizes, assuming the joint is tightened below the gross yield strength of its components.

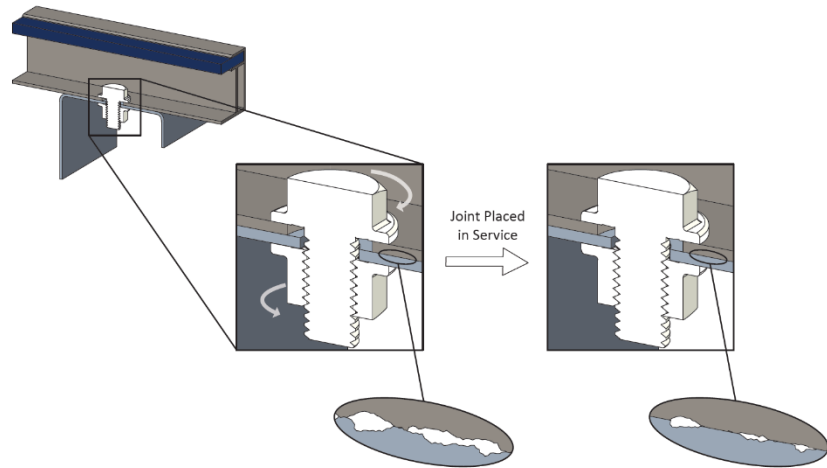

Image 14: When a PV module through-bolted joint is assembled and tightened, the asperities are pressed together, leading to high localized compressive stresses and plastic flattening of the asperities.

Unfortunately, no guide values exist for embedment distances specific to the materials and coatings commonly used in solar PV mounting systems. Until more targeted research is available, a reliable reference is *VDI 2230 Part 1: Systematic Calculation of High Duty Bolted Joints – Joints with One Cylindrical Bolt*, published by the Verein Deutscher Ingenieure. This standard provides conservative guide values for embedment distance based on material and surface roughness (VDI, 2015).

Table 5 of VDI 2230 shows that the estimated embedment distance for a typical through-bolted PV module joint is approximately **0.011 mm**.

Note: The experimental methods necessary to determine the embedment distance (f_z) for a specific bolted joint are outside the scope of this report.

Most bolted joints in solar PV mounting systems are not re-tightened after installation, leading to early relaxation due to embedment. Much of this relaxation occurs immediately after tightening. However, studies have shown that additional relaxation can happen when the joint is first subjected to dynamic loading (Abid, 2015) (Eccles, Preload Loss from Embedding in Bolted Joints, N/A). This behavior is illustrated in Figure 15.

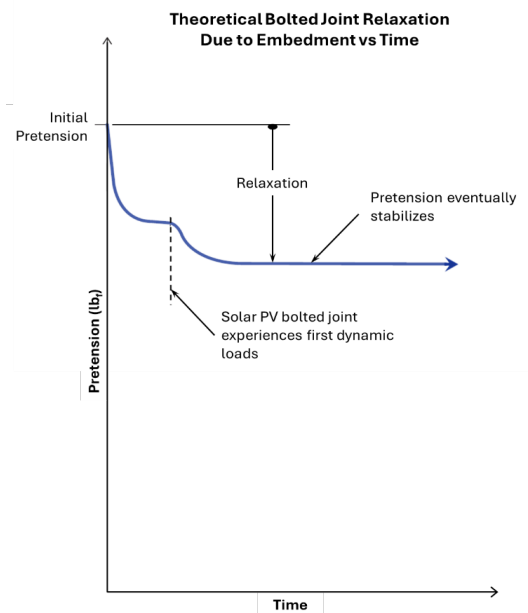

Figure 15: Theoretical relaxation of pretension due to embedment over time in a typical solar PV mounting system bolted joint.

Relaxation due to embedment is normal and should be expected, even in properly designed and assembled joints. While further research is needed, the phenomenon should not be dismissed, particularly in critical mounting system bolted joints.

Ideally, relaxation from embedment should be accounted for during the design phase. In addition, bolt pretension should be verified during the initial testing of any new mounting system joint design.

2.1.3.1 Calculation to Estimate Relaxation Due to Embedment

A designer can estimate the maximum relaxation in a solar PV mounting system bolted joint by considering the embedment distance (f_z) and the bolt stiffness (k_b). The embedment distance must be determined experimentally or from a reliable reference, while bolt stiffness should be calculated using Hooke's Law (Bickford, 2022).

A bolt behaves like a spring, stretching elastically along its length when tightened and storing energy following Hooke's Law (see Image 16). The spring constant of the bolt (k_b) can be estimated using the simplified equation shown in Equation 1.

Equation 1

Where:

- D = Nominal diameter of the bolt (mm² or in²)
- E = Young's Modulus of the bolt material (MPa or psi)
- CL = Clamped length (mm or in)
- L = CL + .8D = Effective length (mm or in)

The bolt stiffness (k_b) and the embedment distance (f_z) affect the relaxation due to embedment. Equation 2, based on VDI 2230 Part 1, defines these relationships (VDI, 2015).

Equation

Where:

- F_z = Relaxation (N or lbf)
- f_z = Embedment distance (mm or in)
- k_b = Bolt stiffness (N/mm or lbf/in)

A bolted joint with a short, stiff bolt is more sensitive to embedment and typically experiences greater relaxation. In contrast, a joint with a longer, more flexible bolt experiences less relaxation under the same conditions. The case study below illustrates this concept by comparing two PV module bolted joints.

2.1.3.2 Case Study: Estimated Relaxation Due to Embedment in Typical PV Module Bolted Joints

Multiple failure investigations into PV module bolted joint failures have been conducted as part of this project and the research team's past work. Although the conditions of the mounting systems and failure events varied widely, a consistent theme was the widespread presence of loose module attachment bolts across the sites (see Glossary for the definition of a loose bolted

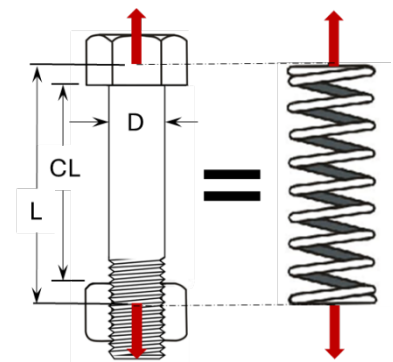

Image 16: A bolt behaves like a spring when it is tightened.

joint). Among these, short through-bolted joints were the most frequently observed. This case study compares theoretical relaxation due to embedment in two bolted joint configurations: a module top-down clamp joint and a module through-bolted joint, using simplified Equations 1 and 2.

A typical top-down clamp uses an M8 stainless steel bolt (8.0 mm diameter) to secure the clamp and module frame to a steel purlin, resulting in a clamped length of approximately 40 mm (see Image 17). In contrast, a typical through-bolted joint uses an M8 stainless steel bolt to attach the module lip directly to the purlin, with a clamped length of just 4.0 mm (see Image 18).

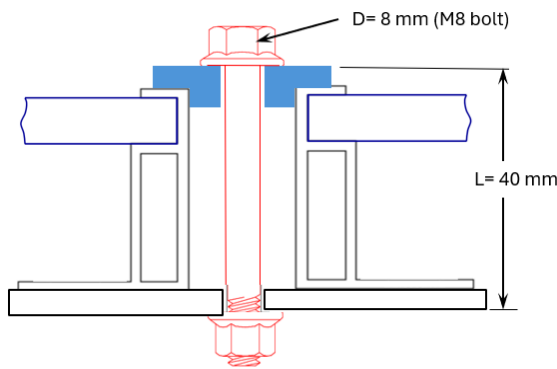

Image 17: Typical PV Module Top-Down Clamp Bolted Joint

M8 Bolt Initial Pretension = 13kN

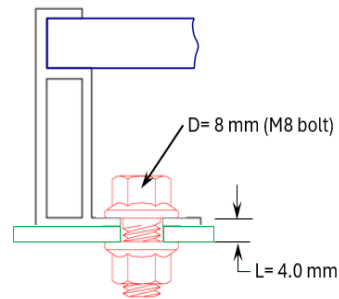

Image 18: Typical PV Module Through-Bolted Joint

M8 Bolt Initial Pretension = 13kN

Module Bolted Joint Type	Approx. Bolt Stiffness K_b (N/mm)	Approx. Embedment Distance (mm)	Initial Pretension (N)	Approx. Relaxation (N)	Estimated Pretension after Relaxation (N)	Approx. % Change in Pretension
Module Top-Down Clamp Joint	222,0778	.0140	13000	-2,882	10,118	-22%
Module Through-Bolted Joint	990,809	0.011	13000	-10,101	2,899	-78%

Table 1: Summary of Case Study Results: Relaxation due to embedment calculation for a typical PV module top-down clamp joint vs through-bolted joint

Table 1 shows that a typical top-down clamp joint may lose up to 2,882 N—approximately 22% of its initial pretension—due to relaxation when placed in service. In contrast, a typical module through-bolted joint may lose up to 10,101 N, or 78% of its initial pretension, under the same conditions (see Addendum A for calculation details).

The relaxation estimates presented in this study are intentionally conservative and likely overestimate actual losses. Nevertheless, they offer valuable guidance for solar PV mounting system designers evaluating specific bolted joints. These findings underscore the importance of using design and assembly methods that minimize relaxation, particularly in module through-bolted joints, which contain short, stiff bolts that are more sensitive to embedment.

The most direct way to minimize embedment is to retighten fasteners multiple times during installation. (Eccles, Preload Loss from Embedding in Bolted Joints, N/A). With each tightening, surface asperities compress further, and the embedment process gradually subsides.

However, repeated retightening is often impractical in solar PV mounting systems due to labor costs and limited access to ‘out of reach’ fasteners. When retightening is impractical, another strategy is to reduce the number of bolted joint interfaces. Fewer interfaces result in a shorter embedment distance. Additionally, important methods for reducing relaxation due to embedment are discussed in the section titled *Minimizing Relaxation Loosening in Solar PV Bolted Joints* later in this report.

2.1.4 Differential Thermal Expansion or Contraction – Within the Solar PV Bolted Joint

Solar PV mounting system bolted joints often connect dissimilar metals, each with a distinct coefficient of thermal expansion (see Table 2). As temperatures change, differential thermal expansion or contraction can cause the bolt pretension to fluctuate. Although this variation is typically slight, designers should account for it—particularly when it leads to relaxation (a loss of pretension).

PV mounting system components are commonly made from aluminum or low-carbon steel and are usually fastened with stainless steel or alloy steel bolts. Aluminum has a higher coefficient of thermal expansion ($22.1 \times 10^{-6}/^{\circ}\text{C}$) than 300-series stainless steel ($17.8 \times 10^{-6}/^{\circ}\text{C}$) or alloy steel ($12.3 \times 10^{-6}/^{\circ}\text{C}$).

As a result, aluminum components expand more than the bolt materials when temperatures rise and contract more when temperatures fall. This differential movement causes bolt pretension to increase when the joint heats above its installation temperature, and to decrease when the temperature drops, resulting in relaxation when the temperature falls below the installation temperature.

Note: *Calculating the exact change in bolt pretension due to differential thermal expansion or contraction involves complex nonlinear behavior and is typically performed with specialized software, especially when temperature changes are extreme. A detailed explanation of these calculations is beyond the scope of this report. Fortunately, the temperature swings in solar PV structures are typically not that large, and simplified methods are acceptable.*

Component	Material	CoF of Thermal Expansion (1/ °C)
Mounting System & Module Frame	6000 Series Aluminum	22.1E-6
Mounting System & Module Frame	Low Carbon Steel	11.7E-6
Bolt or Screw	300 Series Stainless Steel (ISO 3506-1 A2-70)	17.8E-6
Bolt or Screw	Alloy Steel (ISO 898-1 Class 8.8)	12.3E-6

Table 2: Summary of coefficients of thermal expansion for common PV mounting system

2.1.4.1 Case Study: Estimated Relaxation Due to Differential Thermal Contraction

To illustrate the effects of differential thermal contraction on pretension in a typical PV module top-down clamp joint, two examples are presented in Image 19.

In the first example, the joint uses a 300-series stainless steel screw and nut. In the second, it uses an alloy steel screw and nut. In both cases, the joint is tightened at 32 °C (90 °F) but is expected to operate at temperatures as low as -20 °C. The resulting pretension and percentage change in pretension (relaxation) are shown in Table 3.

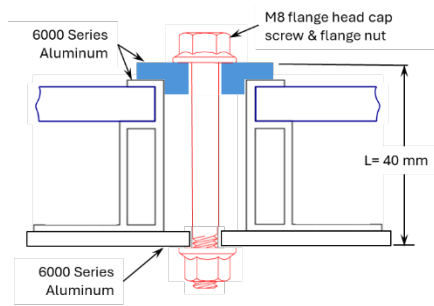

Example #1
*Bolt and nut material: 300 series stainless steel
 Flange nut tightened to a pretension of 13 kN at 32C (90F)*

Example #2
*Bolt and nut material: Alloy steel
 Flange nut tightened to a pretension of 16 kN at 32C (90F)*

Image 19: Information used in the calculation of relaxation due to differential thermal contraction in examples #1 & 2

PV Module Top-Down Clamp Example	Clamped Material	Bolt & Nut Material	Temp. at Installation (°C)	Pretension after Installation (kN)	Lowest Oper. Temp. (°C)	Pretension at Lowest Oper. Temp. (kN)	% Change in Pretension
#1	6000 Series Aluminum	300 series stainless steel	32	13	-20	12.5	-4.0%
#2	6000 Series Aluminum	Alloy steel	32	13	-20	11.6	-10.7%

Table 3: Summary of Case Study Results: Relaxation in a typical PV module top-down clamp due to differential thermal contraction

Table 3 shows that a 300-series stainless steel bolt is expected to lose approximately 4% of its initial pretension when the temperature drops to -20 °C. In contrast, an alloy steel bolt may lose nearly 11%. This larger loss is attributed to the alloy steel's higher coefficient of thermal expansion (see Addendum A for calculation details).

These results indicate that both examples show modest relaxation due to differential thermal expansion and contraction. However, this should not be dismissed during design, as these losses are cumulative and add to other loosening mechanisms discussed in this report.

Increasing the initial bolt pretension is a common method to compensate for relaxation due to differential thermal contraction. When this is not feasible, one or more Belleville springs are often added under the bolt head or nut to maintain preload (See the section on Belleville Springs for more details).

2.2 Minimizing Relaxation Loosening in Solar PV Bolted Joints

As previously mentioned, joint yielding and fretting wear are problematic because they lead to persistent loosening of bolted joints. To mitigate this risk, designers of solar PV mounting systems should avoid joint configurations that allow component yield or fretting.

Embedment and differential thermal contraction are normal loosening mechanisms and should be accounted for in the design of PV bolted joints. When feasible, designers should apply high safety factors to accommodate these effects. However, if large design margins are not possible, relaxation loosening can be reduced by reducing the bolted joint stiffness.

Two common methods for reducing bolt stiffness are described below.

2.2.1 Increase the L/D Ratio of the Bolted Joint

Bolt stiffness (k_b), which largely determines the overall stiffness of a bolted joint, depends on the bolt's cross-sectional area (A), effective clamped length (L), and the Young's modulus of its material, as shown in Equation 1. From this relationship, the commonly used L/D ratio provides a simple metric for comparing bolt stiffness across different joints. It is calculated by dividing the effective clamped length (L) by the nominal bolt diameter (D).

Joints with low L/D ratios ($L/D \leq 1$) are relatively stiff and more sensitive to small dimensional changes—such as embedment—while those with high L/D ratios ($L/D > 3$) are more flexible and less affected. The previous case study demonstrated this effect by comparing relaxation in a top-down PV module clamp joint ($L/D = 5$) with a through-bolted joint ($L/D = 0.5$).

Designers can reduce bolt stiffness (k_s) by increasing the clamped length (L) or by decreasing the nominal bolt diameter (D). Increasing L often involves the use of spacers. In contrast, reducing the bolt diameter is generally impractical unless higher-strength materials are used to maintain the required pretension. A comprehensive evaluation of these trade-offs lies beyond the scope of this report.

2.2.2 The Use of Belleville Springs in Solar PV Bolted Joints

Belleville springs, also known as Belleville washers or disc springs, are named after Julien Belleville, a 19th-century French engineer. These conical springs can be used in solar PV module mounting system bolted joints to help maintain clamp load by compensating for small

dimensional changes caused by relaxation or thermal contraction (see Image 20) (Davet, N/A).

A Belleville spring is a conically shaped disc that flattens at a known spring rate. As bolt pretension increases, the spring compresses along its axis until it becomes flat, at which point it functions like a conventional washer. Once flattened and clamped between the joint and the bolt head or nut, additional tightening stretches only the bolt.

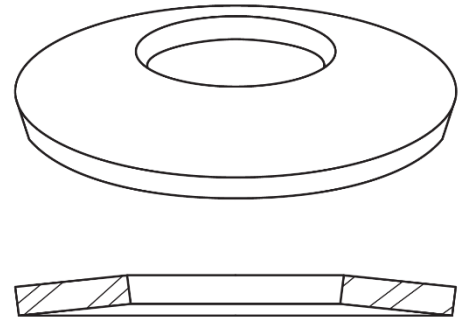

Image 20: Belleville spring in the unloaded state takes the form of a conical spring that flattens at a known spring rate.

If pretension remains constant or increases, the spring remains flat. However, if the joint loosens—due to embedment or thermal contraction, the spring expands slightly, acting as a mechanical buffer that compensates for the dimensional change. The behavior helps maintain preload and reduces the effect of joint relaxation by effectively lowering the overall joint stiffness.

Belleville springs have been successfully integrated into solar PV module through-bolted joints, which are especially prone to relaxation and thermal effects. A white paper by George Davet of Solon Manufacturing Company (Davet, N/A) provides a practical guide for selecting and specifying Belleville springs (Davet, N/A).

Belleville springs have an additional hidden benefit. Their unique shape—flat when fully compressed—can indicate to installers that proper pretension has been achieved. In the field, inspectors can use their shape to assess whether a joint has loosened.

3. Self-Loosening (rotational loosening)

3.1 Friction, a Critical Parameter for Bolted Joint Reliability

Friction is a critical factor in the reliability of bolted joints in solar PV mounting systems. During torque-controlled tightening, friction in the threads and beneath the head of the bolt or nut (whichever is rotated) significantly influences the amount of pretension generated in the bolt (Bickford, 2022).

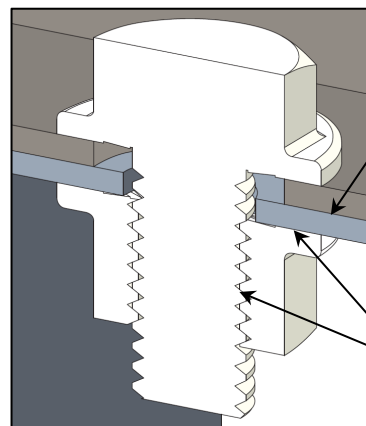

Friction and clamp load at the joint interface prevent joint slip in a properly designed and assembled bolted joint.

Friction in the threads, and under the bolt head and nut, prevents self-loosening in a joint that

Image 21: Friction within the solar PV bolted joint prevents joint slip and the resulting self-loosening in a properly designed and assembled bolted joint.

Once the joint is tightened, this friction helps resist self-loosening by preventing relative rotation between the nut and bolt. Without sufficient friction in the threads and under the bolt and nut head, the nuts would loosen due to the stored energy in the bolt.

In addition to thread and bearing surface friction, most solar PV bolted joints rely on friction at the faying surfaces to transfer shear loads and prevent joint slip (see Image 21). The joint may slip under shear loading if the friction at these interfaces is insufficient. This slippage can result from high cyclic wind loads or lower loads if pretension is inadequate due to improper tightening or preload relaxation.

Friction governs not only the initial pretension achieved during tightening, but also the joint's resistance to self-loosening and slip under service loads. Without sufficient friction, reliable solar PV bolted joints cannot be ensured.

3.2 Explanation of Self-Loosening

Self-loosening is a specific loosening process that affects bolted joints, including those used in solar PV mounting systems. This phenomenon occurs when the initial pretension in a bolt decreases over time due to rotational loosening between the nut and bolt (Eccles, *Triological Aspects of the Self-Loosening of Threaded Fasteners*, 2010).

Gerhard Junker published a seminal paper on self-loosening, supported by extensive follow-up testing. His research demonstrated that self-loosening occurs in joints subjected to repeated transverse slip, rather than axial loading (Junker, 1969). His findings remain highly relevant to modern PV mounting system joints.

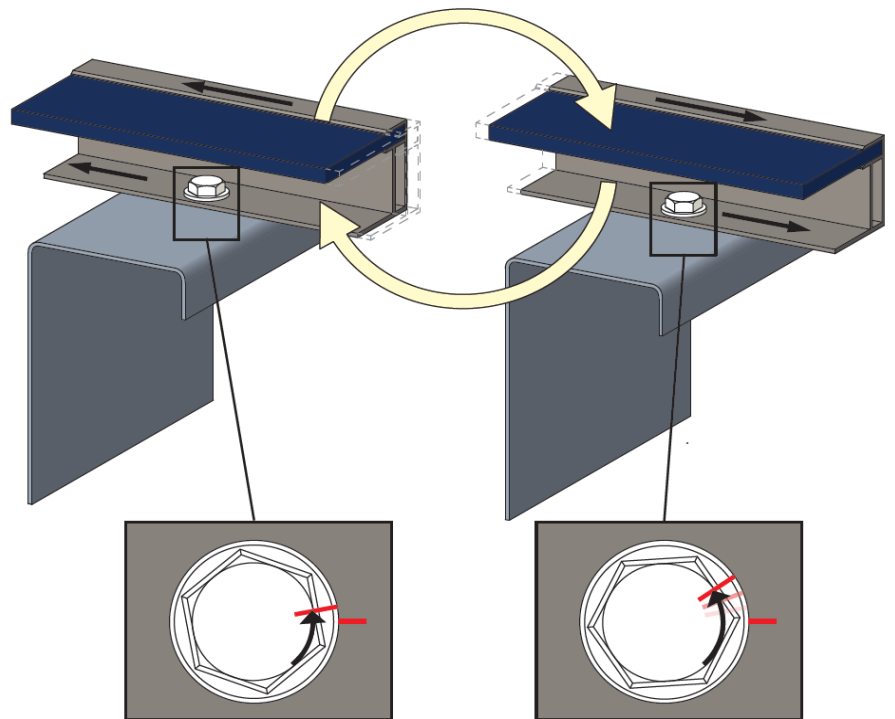

Image 22: Solar PV joints, such as the PV module through bolted joints, will self-loosen if the joint repeatedly slips.

When a bolted joint repeatedly slips under the right conditions, friction in the threads and under the bolt head or nut can momentarily drop, allowing the nut to rotate slightly in the loosening direction. With each slip cycle, this counter-rotation accumulates, leading to a dramatic loss of pretension. In extreme cases, joints using plain nuts and bolts can fully loosen and even become detached (see Image 22).

Self-loosening is a relatively common issue in PV mounting systems, especially in bolted joints

with slotted joint plates when loading is parallel to the slot direction. Fortunately, self-loosening is both detectable and preventable with proper assembly and design strategies.

3.3 The Use of Torque Stripes to Detect Self-Loosening

A common best practice in the solar PV industry is to apply a paint stripe, also known as a torque stripe or witness mark, to the head of a bolt or nut after installation to indicate that the fastener was tightened to the specified torque. When properly applied, the stripe should extend from the bolt threads, across the nut or bolt head, and onto the joint surface, as shown in Image 23 (Biernath, 2017).

This technique is a valuable quality control measure during installation and can also be used during follow-up inspections to detect self-loosening. If the stripe on the bolt is no longer aligned with the stripe on the joint surface, relative rotation between the internal and external threads has occurred, indicating that the joint has loosened, as seen in Image 24.



Image 23: Torque stripes detect whether self-loosening has occurred after installation.

Image 24: Solar PV bolted joint with evidence of repeated joint slip and self-loosening.

3.4 Junker Test

During his research, Junker developed a test apparatus and procedure, now known as the Junker Test, which laid the foundation for modern industry standards such as DIN 25201 and ISO 16130. These standards evaluate the ability of locking fasteners or devices to resist loosening in joints that undergo repeated slipping. Go to <https://www.boltscience.com/pages/junkertestvideo.htm> to see a video explaining and demonstrating the Junker Test.

In a Junker test, a pretensioned bolted joint is subjected to repeated transverse displacement under controlled conditions (e.g., pretension, slip amplitude, frequency), while the bolt pretension is continuously monitored (Junker, 1969). Importantly, the Junker test does not evaluate whether a joint will slip under a known shear load. Instead, it assesses how well a locking fastener or device resists self-loosening when the joint is intentionally made to slip, i.e.,

simulating a failed joint.

Despite this aggressive failure-mode testing, the Junker test remains a valuable method for comparing the relative performance of fasteners and locking devices in applications where redundant loosening protection is desirable.

Test results are typically presented as pretension decay charts, which graph pretension loss over a set number of slip cycles. A fastener or locking device is considered resistant to self-loosening if it retains at least 80% of its initial pretension after 2,000 cycles.

Numerous studies have shown that standard nuts, lock nuts, and helical spring washers loosen quickly under Junker test conditions and provide limited resistance to self-loosening (Junker, 1969). In contrast, wedge-lock washers, high-strength thread adhesives, and lockbolts have demonstrated significantly better performance as shown in Figure 25.

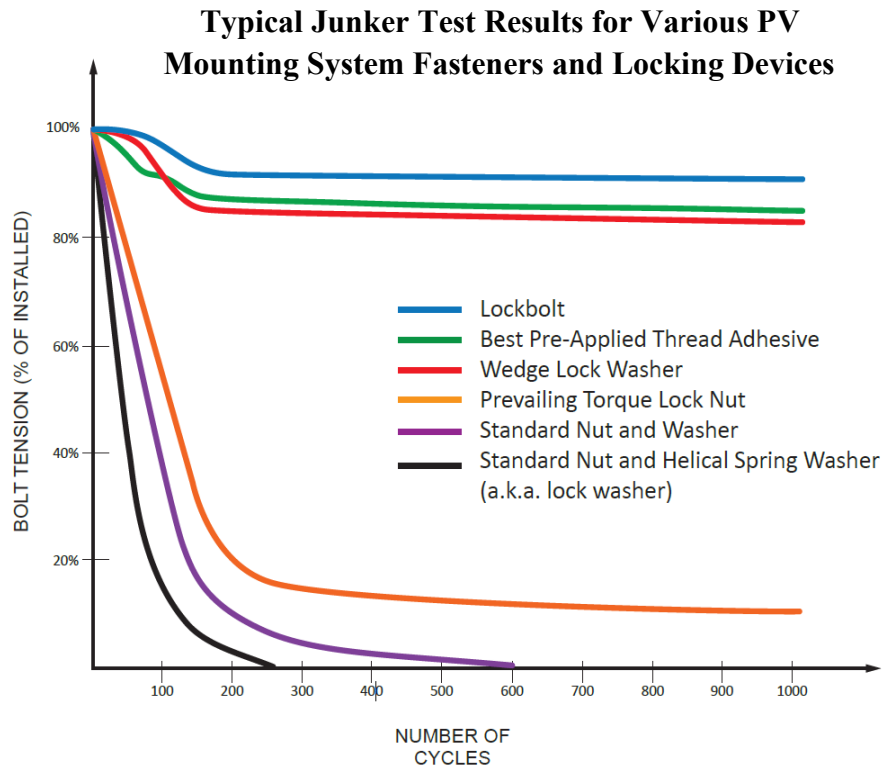

Figure 25: Test results shown here were compiled from previous tests completed by Bolt Science-LTD, Huck International, Inc. and Henkel Corp.

3.5 Prevention of Self-Loosening

Researchers broadly agree that repeated joint slip is the root cause of bolted joint self-loosening. If the bolted joints within a solar PV mounting system resist slip, they will not self-loosen (Junker, 1969). To achieve this, the shear capacity of the bolted joint must always be

higher than the shear loads applied to that joint.

The most effective and widely accepted method for preventing self-loosening in mechanical and structural joints is to design and assemble the joint such that the frictional shear capacity at the faying surface(s) exceeds the expected shear load. This friction-based approach remains the foundation of reliable bolted joint design.

3.5.1 How is shear capacity created in a particular solar PV bolted joint?

The shear capacity generated by friction at the joint interface (faying surface) in a solar PV mounting system depends on two key factors: the clamp load and the static coefficient of friction.

Clamp load is determined by the initial bolt pretension and is affected over time by relaxation mechanisms such as embedment and differential thermal contraction. The coefficient of friction depends on surface characteristics, including roughness, surface treatments, coatings, and contaminants.

These variables must be thoroughly understood by the mounting system designer and carefully controlled during design and installation to achieve consistent and predictable shear capacity. It is a complex challenge, far from simple.

3.5.2 What is the shear load applied to a particular solar PV bolted joint?

Predicting the shear load applied to a specific solar PV bolted joint may seem straightforward at first glance. However, the physics of load transfer in PV mounting systems is often complex, particularly under dynamic loading conditions.

Solar PV mounting systems are generally lightweight and flexible compared to traditional structures such as bridges and buildings. As a result, they can undergo significant deflections and movement in response to wind loads, amplifying the forces experienced at individual bolted joints. This amplification can lead to unexpectedly high shear loads. (Cain, 2015). In practice, it's not so straightforward.

While advanced numerical techniques can predict shear loads at the joint level, simplified and practical methods have yet to be developed. The solar PV industry is increasingly aware of this gap, and there is growing interest in research and standards that address it.

The principle of preventing bolted joint self-loosening through clamp load and friction at the joint interface (faying surface) is well established in mechanical and structural engineering. It is not new to the solar PV industry either.

- UL 2703, *Standard for Safety for Mounting Systems, Mounting Devices, Clamping/Retention Devices, and Ground Lugs for Use with Flat-Plate Photovoltaic Modules and Panels*, (UL, 2024) requires that the slip resistance (shear capacity) of a bolted joint exceeds the shear load associated with either the minimum design load

rating or the manufacturer's specified product load rating, as stated in Section 6.6. Section 21 of the standard defines a mechanical loading test that verifies the bolted joint's ability to resist slipping under these loading conditions.

- The forthcoming *ASCE Manual of Practice for Solar PV Structures* proposes that connections using materials and components covered by AISC 360 (ANSI/ASCE, 2022) and the RCSC: *Specification for Structural Joints Using High-Strength Bolts* (RCSC, 2020) be treated as traditional structural bolted joints (connections) and designed in accordance with those specifications. (see Glossary for the definition of traditional structural fastener)

If this guidance is adopted, many bolted joints $\frac{1}{2}$ " in diameter and larger may be classified as slip-critical (see Glossary for definition of slip-critical). This classification would represent a significant step toward controlling friction resistance and mitigating self-loosening and other slip-related failure mechanisms.

While debate continues within the solar PV industry over whether bolted joints in solar PV mounting systems fall under the scope of AISC 360 and RCSC, and whether they should be classified as slip-critical, this discussion is beyond the scope of this report.

3.6 Devices Effective at Resisting Self-loosening

Given the complexity and uncertainty surrounding the capacity and loading of solar PV bolted joints, many PV mounting system manufacturers and site owners acknowledge that periodic joint slip may occur. To mitigate the risk of self-loosening, they are encouraged to select one of the following device types.

While these devices typically perform well in resisting loosening, it is important to note that they do not address the root cause: repeated joint slip.

3.6.1 Lockbolts

A lockbolt is a mechanically fastened, two-piece structural fastener consisting of a pin and a collar, designed to form a high-strength, vibration-resistant joint (see Image 26). During installation, a specialized tool pulls the pin to draw the joint components together.

Unlike traditional threaded fasteners, lockbolt tensioning does not rely on torque measurement and is unaffected by friction variations. The assembled joint can be quickly inspected using the witness marks on the crimped collar, which confirm proper installation.

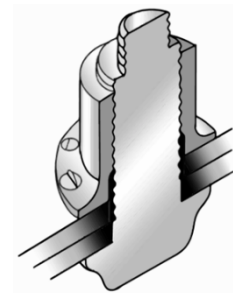

Image 26: Lockbolts are inherently resistant to self-loosening.

Due to their permanent, interference-based design, lockbolts are inherently resistant to self-loosening and do not require additional locking devices or thread adhesives. They are widely considered a superior alternative to conventional threaded fasteners for critical structural joints,

particularly when the solar PV site owner can justify the added cost of specialized installation tools (Ness, 2020).

3.6.2 Thread Lockers/Adhesives

Many commercially available pre-applied, high-strength thread lockers and adhesives lock the internal and external threads together and typically resist self-loosening (Gong, 2022).

Contractors apply traditional liquid thread lockers to bolt or nut threads in the field, which introduces variability in the amount and placement of the thread locker. On the other hand, pre-applied thread lockers are applied under controlled factory conditions, ensuring uniform coating thickness, even distribution, and complete cure compatibility.

The highest-strength pre-applied thread lockers typically contain pressure-activated microencapsulated beads (Image 27). When the fastener is installed, the microencapsulated beads break, releasing an activator and initiating curing.

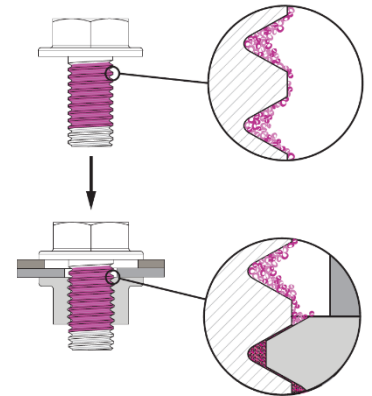

Image 27: Pre-applied thread locker is activated upon assembly of the bolted joint.

Depending on the specific chemistry and formulations, microencapsulated thread lockers can be assembled between 40°F and 150°F and typically cure within 24 hours after assembly. To ensure the highest strength thread adhesive bond, the mating nuts must be clean and lubricant-free

The highest-strength thread adhesives are permanent, and the locked fasteners cannot be retightened or disassembled without damaging them.

3.6.3 Wedge Lock Washers

Wedge lock washers are hardened with cams on one side and serrations on the other, as shown in Image 28. The serrations on the outside of the washer embed into the joint surfaces, and the cam surfaces lock the fastener by a wedging action. Wedge washers come in matched pairs and are typically pre-oriented and glued with a weak adhesive to facilitate assembly.

In through-bolted applications, installers must add wedge washers under the nut and bolt, which slows installation and increases cost (see Image 29).

However, solar PV site managers often justify the increased costs of wedge washers because of their ability to resist self-loosening (Gong, 2022). Unlike thread lockers, the washers allow the bolted joint to be disassembled or retightened.

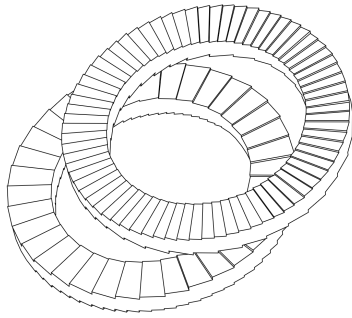

Image 28: Wedge lock washers must be assembled in pairs.

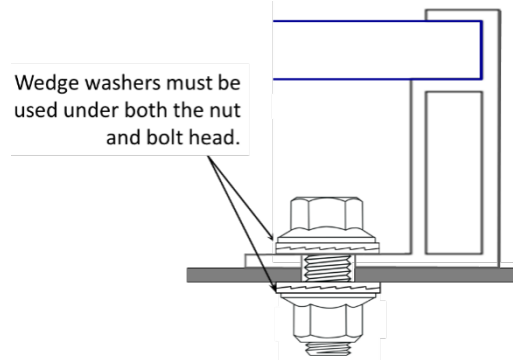

Image 29: Wedge lock washers must be assembled in pairs.

3.6.4 Caution on Using Locking Fasteners / Devices

While threaded fastener locking devices, adhesives, and lockbolts may prevent self-loosening in service, they will not prevent the joint from slipping if the friction in the faying surface is insufficient to carry the shear loads. As a result, threaded fasteners and lockbolts may experience repeated bending loads if the joint slips and may be prone to fatigue failure. (Eccles, 2010)

Solar PV mounting system manufacturers and site owners should exercise caution when selecting thread lockers, locking devices, or lockbolts for use in joints that may be overloaded, prone to slipping, or prone to opening. Bolted joints that experience repeated slip are susceptible to relaxation due to fretting wear and, more critically, at risk of fatigue failure.

3.7 Devices/Methods Ineffective at Resisting Self-loosening

Many solar PV mounting system manufacturers and solar PV site owners have chosen one of the following devices to reduce the risk of bolted joint self-loosening. Unfortunately, testing has shown these devices are generally **ineffective** at resisting self-loosening.

3.7.1 Helical spring washers (a.k.a. lock washers)

Solar PV mounting system manufacturers often specify helical spring washers on the misguided belief that they will lock the surfaces under the bolt head and nut to the joint and prevent self-loosening if the joint slips during the life of the solar PV structure (see Image 30).

When tightened, a helical washer becomes compressed until it is flat, and two sharp edges cut into the contact surfaces of the clamped plate and nut (or bolt head). Theoretically, the frictional forces on the bearing surfaces lock the bolt and nut into place. But Junker's research has shown that lock washers are ineffective in resisting self-loosening (see Image 31) (Junker, 1969) (Eccles, 2010).

For these reasons, automotive manufacturers have virtually eliminated helical spring washers

in modern vehicles.



Image 30: Typical helical spring washer.



Image 31: Helical washer in a loose module through-bolted joint.

To watch a bolted joint with a helical spring washer loosening during a Junker test, visit <https://www.boltscience.com/pages/helicalspringwashers.htm>.

3.7.2 Serrated flange bolts and nuts

Serrated flange bolts and nuts are also commonly specified in module attachments and inter-rack solar PV bolted joints to prevent self-loosening (see Image 32). This type of nut and bolt has an enlarged head diameter, and the bearing contains serrations or wedges that typically 'cut' into the contact surface of the clamped component during tightening. This action tends to increase the friction coefficient between the head and the clamp component and, in theory, creates a resistance to self-loosening.



Image 32: Typical serrated flange bolt and nut.

Research has shown that if a bolted joint repeatedly slips, the material under the nut serrations wears down quickly, making them ineffective at resisting self-loosening (Gong, 2022).

3.7.3 Lock Nuts (a.k.a. prevailing torque nuts)

Lock nuts are used widely in the solar PV industry under the misguided belief that they prevent self-loosening. Unfortunately, lock nuts will self-loosen if the joint repeatedly slips.



Image 33: Nylon insert, prevailing torque nut (a.k.a. "lock nut")

Lock nuts resist rotation through deformation or interference between the internal and external threads. The torque required to 'run' the nut down on the bolt is the prevailing torque, hence the name prevailing torque nuts.



Image 34: Typical all-metal prevailing torque nut (a.k.a. lock nut)

These nuts come in two types: all-metal and

nylon-insert. All metal lock nuts contain a distorted internal thread that causes a slight interference with the external thread of the mating bolt (see Image 34). Nylon-insert lock nuts contain a threadless ring of nylon, which interferes with the external thread of the mating bolt (see Image 33).

Research has shown that the increased friction in the threads generated by the prevailing torque feature of the nuts does not prevent the initial self-loosening of a bolted connection during the Junker Test. However, self-loosening stops when the loosening torque equals the prevailing torque. In other words, lock nuts will generally not loosen completely if the axial loading on the bolted joint is relatively low (Eccles, 2010).

In summary, lock nuts do not prevent self-loosening and will gradually loosen if a solar PV bolted joint experiences periodic slip. Although the joint becomes loose, the lock nut typically remains attached to the bolt. In other words, while lock nuts do not maintain pretension or keep the joint tight, they generally prevent complete joint separation.

Given their relatively low cost, lock nuts can be a worthwhile investment in solar PV structures to reduce the risk of module detachment or separation of structural members.

3.7.3.1 Considerations for Nylon-Insert Lock Nuts (a.k.a. nylock nuts, or nylon insert prevailing torque nuts)

Solar PV mounting system manufacturers and solar PV site managers often specify nylon-insert prevailing torque nuts. Unfortunately, the nylon inserts are sensitive to temperature, moisture, and ultraviolet radiation (UV) exposure. If the nuts are not correctly specified and assembled in the field, this characteristic can result in cracking or degradation of the nylon and the locking ability.

Nylon is ductile at room temperatures, but becomes brittle at low temperatures, especially in dry conditions, making the installation of the nuts challenging unless the nuts are kept warm (Fastenal, N/A). Nylon becomes brittle when exposed to ultraviolet (UV) light because the UV radiation breaks down the molecular bonds in the nylon's polymer chains. This behavior is problematic in solar PV mounting systems, where the nylon ring nut is exposed to sunlight unless the nut manufacturer adds blockers or stabilizers to the nylon.

Solar PV mounting system manufacturers and solar PV site managers should consider the specification and assembly of nylon-insert nuts to avoid cracking and a loss of locking ability (see Image 35).

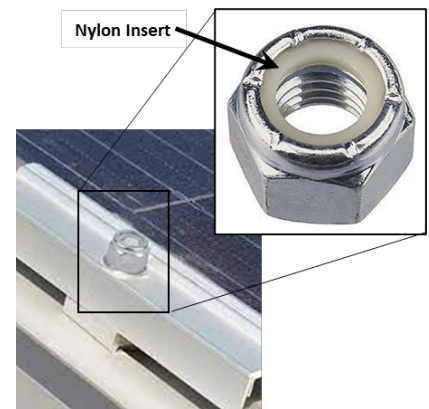

Image 35: The use of nylon lock nuts can be problematic in solar PV joints unless they are correctly specified.

Industry Misunderstanding: “Vibration causes Solar PV Mounting System Bolted Joints to Loosen”. Extensive research has revealed two fundamental types of bolted joint loosening: relaxation loosening (non-rotational) and self-loosening (rotational) CITATION Joh22 \1 1033 (Bickford, 2022). Solar PV mounting bolted joints commonly experience both types of loosening. While vibration can influence both, it's important to understand that vibration is not the root cause of either loosening type.

4. Top 10 Tips to Avoid Loosening in Solar PV Mounting System Bolted Joints

1. Design for High Pretension to Prevent Joint Separation or Slip

Solar PV bolted joints should be designed and assembled so that the pretension is high enough to prevent the faying surfaces from separating or slipping under the loads experienced during the life of the structure, especially during high-wind events.

2. Match Hole or Slot Geometry to Bolt Size

Ensure that through-holes and slots match the bolt size and conform to accepted design standards (e.g., RCSC) to promote proper load transfer and minimize joint movement. Oversized holes and slots are problematic, especially if the washer is not specified correctly.

3. Use Properly Specified Washers or Flanged Fasteners

- a. Specify Washer Hardness: Washers must be as hard or harder than the bolt or nut (verified by microhardness testing) to prevent yielding at the contact surface.
- b. Specify Washer Thickness and Size: **Use** washers of sufficient thickness to span oversized holes or slots, distribute the clamp load, and remain flat during tightening. For additional information, see *Proposed Specifications for Clearance Holes and Washers* (Ness and Robinson, 2026).

4. Avoid Use of Star Washers at Bolted Joint Interface (to create an electrical bond)

Star washers should not be used as an improvised way to create an electrical bond in mounting system bolted joints exposed to dynamic loading, unless approved by the mounting system manufacturer, and certified under UL 2703.

5. Eliminate or Reinforce ‘Soft’ Bolted Joints

Ensure the clamped components in soft bolt joints are thick enough to prevent yielding under full bolt pretension. If necessary, use spacers to eliminate air gaps.

6. Account for Relaxation Due to Embedment During Design and Installation

- a. Estimate and design for relaxation due to embedment using VDI 2230 guidelines or experimental data.
- b. Lower bolt stiffness to reduce preload loss due to embedment by increasing the

L/D ratio, or incorporate one or more Belleville springs according to the referenced white paper by Solon Mfg.

- c. Where possible, retighten bolted joints prone to relaxation due to embedment early in the mounting system's life.
- 7. Account for Relaxation Due to Thermal Contraction During Design**
- a. Estimate and design for relaxation due to differential thermal contraction. Although this relaxation may be modest, it should not be dismissed as it is cumulative and adds to other loosening mechanisms discussed in this report.
 - b. Relaxation due to differential thermal contraction can be compensated for by increasing the initial bolt pretension.
 - c. When this is not feasible, one or more Belleville springs are often added under the bolt head or nut to maintain preload according to the referenced white paper by Solon Mfg.
- 8. Use Torque Stripes for Quality Control and Monitoring**
- Apply torque/witness marks across the bolt/nut and joint surface during installation to verify tightening and detect loosening during future inspections.
- 9. Avoid Misguided Reliance on Ineffective Devices – To Resist Self-Loosening**
- Do not rely on helical spring washers, standard lock nuts, or serrated flange bolts for critical joints. Junker testing has shown that these devices are ineffective at resisting self-loosening under slip conditions.
- a. Lock nuts do not prevent self-loosening and will gradually loosen if a solar PV bolted joint experiences periodic slip. Although the joint becomes loose, the lock nut typically remains attached to the bolt. In other words, while lock nuts do not maintain pretension or keep the joint tight, they generally prevent complete joint separation. Given their relatively low cost, lock nuts can be a worthwhile investment in solar PV structures to reduce the risk of module detachment or structural member separation.
- 10. Use Thread Locking Devices Judiciously**
- Consider using wedge-lock washers, lockbolts, or high-strength thread adhesives in bolted joints prone to self-loosening. While these devices are effective at resisting loosening, they do not prevent joint slip—the underlying cause of self-loosening. Joints that experience repeated slips are vulnerable to preload relaxation due to fretting wear and, more critically, are at risk of fatigue failure.

5. Conclusions

This report outlines the underlying mechanisms and contributing factors of bolted joint loosening in solar PV mounting systems and provides actionable strategies to mitigate them. Drawing on research supported by the U.S. Department of Energy's Solar Energy Technologies Office, it establishes that loosening is typically a consequence of overlooked or misunderstood design and assembly issues, particularly preload relaxation and joint slip.

By categorizing loosening into two main types, relaxation loosening (non-rotational) and self-loosening (rotational), and identifying their root causes, the paper presents a framework for PV

designers, manufacturers, and site owners to improve joint reliability. Critical insights include the role of embedment, component yield, fretting wear, and thermal contraction in pretension loss, as well as the failure of many commonly used locking devices under dynamic conditions.

To address these risks, the report offers practical guidance—ranging from washer and fastener specification, to joint geometry, to the judicious use of locking solutions. Testing methods such as the Junker Test, along with field inspection tools like torque stripes, are emphasized as effective quality assurance techniques.

Ultimately, increasing the reliability of solar PV bolted joints will reduce O&M costs, prevent system downtime, and enhance safety across large-scale PV installations. The guidance provided here aims to empower the industry with the tools and the basic understanding necessary to address this persistent issue and design for long-term structural performance.

6. References

- Abid, M. U. (2015). An Experimental Study on the Relaxation of Bolts. *IIUM Engineering Journal*, Volume 16.
- ANSI/ASCE. (2022). *Specification for structural steel buildings (ANSI/AISC 360)*. Reston, VA: ANSI/ASCE.
- Bickford, O. (2022). *Introduction to the Design and Behavior of Bolted Joints*. Boca Raton: CRC Press.
- Biernath. (2017, August 24). *Torquing - the Solar Installation Mystery - Part 1!* Retrieved from LinkedIn: <https://www.linkedin.com/pulse/torquing-solar-installation-mystery-helge-biernath/>
- Cain, B. P. (2015). Wind loads on utility scale solar power plants. *International conference on wind engineering SEAOC convention proceedings*. Sacramento, CA: SEAOC.
- Davet. (N/A). *Using Belleville Springs to Maintain Bolt Preload*. Chardon: Solon Manufacturing, Company.
- Eccles. (2010). *Triological Aspects of the Self-Loosening of Threaded Fasteners*. Lancashire, UK: Jost Institute for Tribotechnology, University of Central Lancashire.
- Eccles. (N/A). *Preload Loss from Embedding in Bolted Joints*. Chorley: Bolt Science, LTD.
- Fastenal. (N/A, N/A N/A). *Nylon Insert Lock Nuts - Nylon Pushing Out or Fracturing*. Retrieved from Fastenal: <https://www.fastenal.com/fast/services-and-solutions/engineering/nylon-insert-lock-nuts#>
- Gong, L. F. (2022). Review on anti-loosening methods for threaded fasteners. *Chinese Journal of Aeronautics*, 47-61.
- Junker, G. (1969). New Criteria for Self-Loosening of Fasteners Under Vibration. *International Automotive Engineering Congress and Exposition* (p. 22). Warrendale, PA: SAE International.
- Ness. (2020). *A Tale of Two Solar Racking System Fasteners: Threaded vs. Lockbolt*. Fremont, CA: Nextracker.
- Ness, J., & Wigginton, K. (2026). *Exploring electrical bonding in PV structural joints*. Lawrence Berkeley National Laboratory.
- Ness, J., & Robinson, G. (2026). *Proposed specifications for clearance holes and washers*. Lawrence Berkeley National Laboratory.
- RCSC. (2020). *Specification for structural joints using high-strength bolts*. Chicago, IL: American Institute of Steel Construction.

- UL. (2024). *Mounting Systems, Mounting Devices, Clamping/Retention Devices, and Ground Lugs for Use with Flat-Plate Photovoltaic Modules and Panels*. Northbrook, IL: UL Solutions.
- VDI. (2015). *Systematic Calculation of Highly Stressed Bolted Joints – Joints with One Cylindrical Bolt*. Dusseldorf, Germany: Engl. VDI-Gesellschaft Produkt- und Prozessgestaltung.
- Yibing Lou, J. Z. (2024, July 4th). *Static and Dynamic Response Analysis of Flexible Photovoltaic Mounts*. Retrieved from WWW.MDPI.com: <https://www.mdpi.com/2075-5309/14/7/2037>

7. Addendum A – Relaxation Due to Embedment Case Study Calculations



Matrix Engineering, LLC
12986 Valley View Road
Eden Prairie, MN 55344

Client: SETO
Project #: 22767
Project Title: Solar Panel Installation Research

Calculated By: M. Dittmer
Checked By: J.Ness

Date: 05/12/25
Date: 05/12/25

Preload Loss Due to Embedment (M8 ISO 3506-1 A2-70, 40mm clamp length)

Where:

D = Nominal diameter of the bolt

$$D := 8 \text{ mm}$$

E = Young's Modulus of the bolt material

$$E := 190000 \text{ MPa}$$

L = Clamp length of the joint

$$L := 40 \text{ mm}$$

L_{eff} = Effective clamp length of the joint

$$L_{eff} := L + 0.8 \cdot D = 46.4 \text{ mm}$$

k_b = Bolt stiffness

$$k_b := \frac{\pi \cdot D^2 \cdot E}{4 \cdot L_{eff}} = 205828 \frac{N}{mm}$$

f_z = Embedment distance

$$f_z := 0.014 \text{ mm}$$

F_z = Relaxation

$$F_z := f_z \cdot k_b = 2882 \text{ N}$$

P = Starting bolt pretension

$$P := 13000 \text{ N}$$

ΔP = Percent change in pretension

$$\Delta P := \frac{F_z}{P} = 0.222$$

P_{final} = Final bolt pretension after embedment

$$P_{final} := P - F_z = 10118 \text{ N}$$

- VDI 2230 Part I, Section 5.4.2.3.

Preload Loss Due to Embedment (M8 ISO 3506-1 A2-70, 4mm clamp length)

Where:

D = Nominal diameter of the bolt

$$D := 8 \text{ mm}$$

E = Young's Modulus of the bolt material

$$E := 190000 \text{ MPa}$$

L = Clamp length of the joint

$$L := 4 \text{ mm}$$

L_{eff} = Effective clamp length of the joint

$$L_{eff} := L + 0.8 \cdot D = 10.4 \text{ mm}$$

k_b = Bolt stiffness

$$k_b := \frac{\pi \cdot D^2 \cdot E}{4 \cdot L_{eff}} = 918312 \frac{\text{N}}{\text{mm}}$$

{x:Null}

f_z = Embedment distance

$$f_z := 0.011 \text{ mm}$$

F_z = Relaxation

$$F_z := f_z \cdot k_b = 10101 \text{ N}$$

P = Starting bolt pretension

$$P := 13000 \text{ N}$$

ΔP = Percent change in pretension

$$\Delta P := \frac{F_z}{P} = 0.777$$

P_{final} = Final bolt pretension after embedment

$$P_{final} := P - F_z = 2899 \text{ N}$$

- VDI 2230 Part I, Section 5.4.2.3.

8. Addendum B – Differential Thermal Contraction Case Study Calculations

Preload Loss or Gain Due to Heating Thermal Effects (8 mm bolts - 4140, 40mm joint)
At Mean Preload of 16,000 N

Where:

l_K = Clamped Length	$l_K := 40 \text{ mm}$
α_S = Coefficient of thermal expansion of the 4140 bolt	$\alpha_S := 12.3 \cdot 10^{-6} \cdot \frac{1}{\Delta^\circ\text{C}}$
α_P = Coefficient of thermal expansion of the aluminum material	$\alpha_P := 22 \cdot 10^{-6} \cdot \frac{1}{\Delta^\circ\text{C}}$
ΔT_S = Temperature change experienced by the bolt	$\Delta T_S := -52 \Delta^\circ\text{C}$
ΔT_P = Temperature change experienced by the aluminum	$\Delta T_P := \Delta T_S$
E_{SIR} = Young's modulus of the 4140 bolt at 32°C	$E_{SIR} := 200000 \text{ MPa}$
E_{ST} = Young's modulus of the 4140 bolt at -20°C	$E_{ST} := 202000 \text{ MPa}$
E_{PIR} = Young's modulus of the clamped aluminum joint at 32°C	$E_{PIR} := 67000 \text{ MPa}$
E_{PT} = Young's modulus of the clamped aluminum joint at -20°C	$E_{PT} := 70000 \text{ MPa}$
k_{bolt} = Stiffness constant of the bolt at 32°C (see VDI 2230 Part 1, Section 5.1.1)	$k_{bolt} := 181851 \frac{\text{N}}{\text{mm}}$
k_{joint} = Stiffness constant of the Aluminum joint at 32°C (see VDI 2230 Part 1, Section 5.1.2)	$k_{joint} := 201450 \frac{\text{N}}{\text{mm}}$
F_{VIR} = Mean bolt preload at 32°C	$F_{VIR} := 16,000 \text{ N}$
ΔF_{Vth3} = Change in the preload as a result of a temperature difference from 32°C to -20°C at mean preload*	

$$\Delta F_{Vth3} := F_{VIR} \cdot \left(1 - \frac{\frac{1}{k_{bolt}} + \frac{1}{k_{joint}}}{\frac{E_{SIR}}{k_{bolt} \cdot E_{ST}} + \frac{E_{PIR}}{k_{joint} \cdot E_{PT}}} \right) + \frac{l_K \cdot (\alpha_S \cdot \Delta T_S - \alpha_P \cdot \Delta T_P)}{\frac{E_{SIR}}{k_{bolt} \cdot E_{ST}} + \frac{E_{PIR}}{k_{joint} \cdot E_{PT}}} \quad \Delta F_{Vth3} = 1376 \text{ N}$$

* A negative value for ΔF_{Vth3} corresponds to an increase in bolt preload.

References:

- VDI 2230 Part I, Section 5.4.2.3.
- Bickford, John H., *Introduction to the Design and Behavior of Bolted Joints – Non Gasketed Joints*, 4th ed. Boca Raton, FL: CRC Press, 2008. pp. 266-271.

**Preload Loss or Gain Due to Heating Thermal Effects (8 mm bolts - A2-70, 40mm joint)
At Mean Preload of 13,000 N**

Where:

l_K = Clamped Length	$l_K := 40 \text{ mm}$
α_S = Coefficient of thermal expansion of the A2-70 bolt	$\alpha_S := 17.8 \cdot 10^{-6} \cdot \frac{1}{\Delta^\circ\text{C}}$
α_P = Coefficient of thermal expansion of the aluminum material	$\alpha_P := 22 \cdot 10^{-6} \cdot \frac{1}{\Delta^\circ\text{C}}$
ΔT_S = Temperature change experienced by the bolt	$\Delta T_S := -52 \Delta^\circ\text{C}$
ΔT_P = Temperature change experienced by the aluminum	$\Delta T_P := \Delta T_S$
E_{SRT} = Young's modulus of the A2-70 bolt at 32°C	$E_{SRT} := 200000 \text{ MPa}$
E_{ST} = Young's modulus of the A2-70 bolt at -20°C	$E_{ST} := 202000 \text{ MPa}$
E_{PRT} = Young's modulus of the clamped aluminum joint at 32°C	$E_{PRT} := 67000 \text{ MPa}$
E_{PT} = Young's modulus of the clamped aluminum joint at -20°C	$E_{PT} := 70000 \text{ MPa}$
k_{bolt} = Stiffness constant of the bolt at 32°C (see VDI 2230 Part 1, Section 5.1.1)	$k_{bolt} := 181851 \frac{\text{N}}{\text{mm}}$
k_{joint} = Stiffness constant of the Aluminum joint at 32°C (see VDI 2230 Part 1, Section 5.1.2)	$k_{joint} := 201450 \frac{\text{N}}{\text{mm}}$
F_{VRT} = Mean bolt preload at 32°C	$F_{VRT} := 13000 \text{ N}$
ΔF_{Vth} = Change in the preload as a result of a temperature difference from 32°C to -20°C at mean preload*	

$$\Delta F_{Vth1} := F_{VRT} \cdot \left(1 - \frac{\frac{1}{k_{bolt}} + \frac{1}{k_{joint}}}{\frac{E_{SRT}}{k_{bolt} \cdot E_{ST}} + \frac{E_{PRT}}{k_{joint} \cdot E_{PT}}} \right) + \frac{l_K \cdot (\alpha_S \cdot \Delta T_S - \alpha_P \cdot \Delta T_P)}{\frac{E_{SRT}}{k_{bolt} \cdot E_{ST}} + \frac{E_{PRT}}{k_{joint} \cdot E_{PT}}} \quad \Delta F_{Vth1} = 516 \text{ N}$$

* A negative value for ΔF_{Vth1} corresponds to an increase in bolt preload.

References:

- VDI 2230 Part I, Section 5.4.2.3.
- Bickford, John H., *Introduction to the Design and Behavior of Bolted Joints – Non Gasketed Joints*, 4th ed. Boca Raton, FL: CRC Press, 2008. pp. 266-271.

